

Architectural Terra Cotta

Recreating the Past
Shaping the Future





Main Office

6860 South Abbott Road
Orchard Park, New York 14127
tel 716.649.7490
toll free 1.888.214.3655
www.BostonValley.com

General Inquiries

info@bostonvalley.com

Estimating

estimating@bostonvalley.com

Sales Support

sales@bostonvalley.com

Sales representatives are available across many regions of the US, Canada and Asia. Please contact our main office for more details.

TABLE OF CONTENTS

Company & Product Overview | 5

Project Installations: Restoration | 11

Project Installations: New Construction | 27

Terra Cotta Manufacturing Process | 41

Extrusion Die Catalog | 63

Performance & Sustainability | 77



Through constant pursuit of technological innovations and creative problem solving, architectural terra cotta has been brought into the modern age.

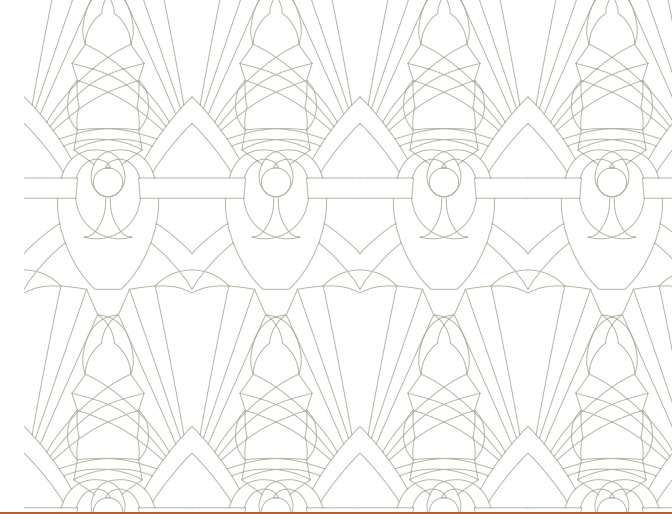

COMPANY & PRODUCT OVERVIEW

Our Company | 6

OUR TEAM

Product Introduction | 8

TERRA COTTA PRODUCTS

TERRA COTTA PROPERTIES

LEAD TIMES OF TERRA COTTA

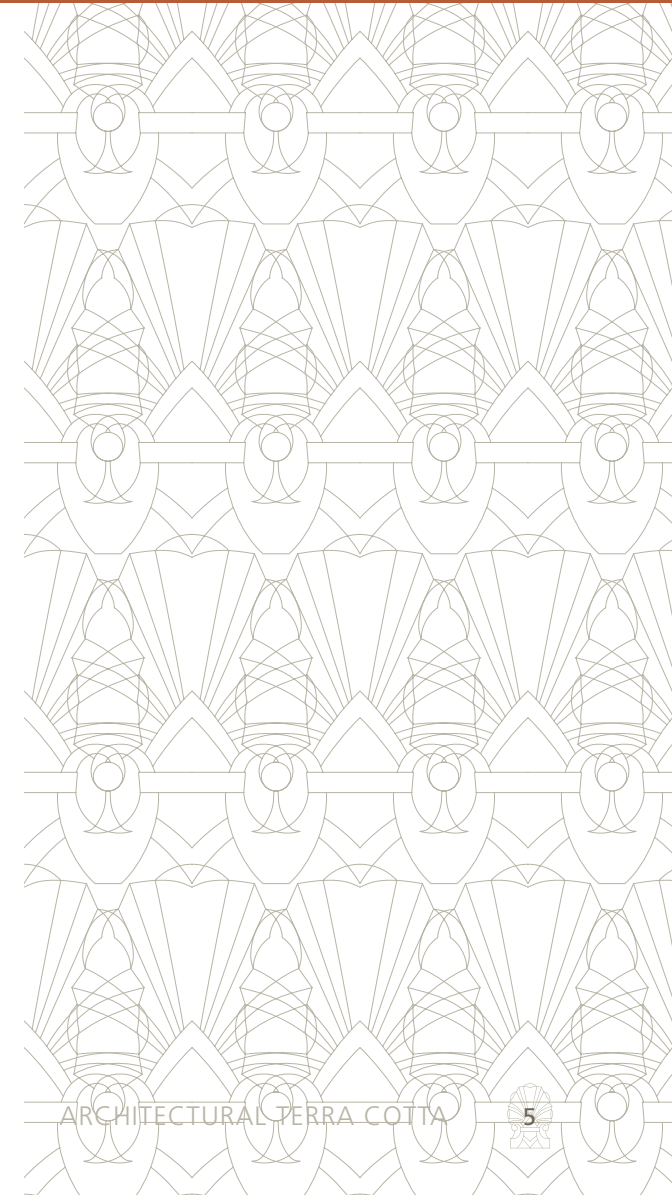



Boston Valley Terra Cotta will support its clients from planning through installation with expert personnel in all areas of the process. Our passion for ceramic innovation drives us to constantly explore new and old technologies to push the envelope in quality, design and service.

OUR COMPANY

BOSTON VALLEY TERRA COTTA WAS ESTABLISHED by the Krouse family in 1981 following the purchase of Boston Valley Pottery, a company which had been in existence since 1889. Originally a brick manufacturing facility and later a clay pot manufacturer, Boston Valley Pottery was converted to an architectural terra cotta facility by the Krouses. Utilizing both superior ceramic engineering knowledge and sculpting talent, Boston Valley Terra Cotta has become one of the leading manufacturers of architectural terra cotta globally.

Boston Valley commenced operations with the restoration of the Guaranty Building, a Louis Sullivan landmark in Buffalo, New

York. Since that time, the company has been awarded contracts for some of the most notable buildings around the country. We are awarded contracts based not only on the cost of our product but also because of our ability to meet and exceed expectations in regard to service and the quality of our terra cotta products. To date, over 2000 contracts have been carried out to completion. Our facility has grown into a state of the art operation with 180,000 square feet of work space and over 150 employees operating two shifts per day. Our management team has over 30 years of experience in design, engineering, drafting, model and mold making, clay body and glaze development, and customer service.



Our Team

Boston Valley Terra Cotta has extremely qualified people in every department. Production is closely monitored and directed by our management team; each employee takes pride in his or her work. Our employees have strong roots in the community and have made Boston Valley Terra Cotta their career. By the fact that we are a corporation with closely held stock, primarily in the hands of the Krouse family, we have a vested interest in seeing that our product is of the very highest quality. Our family values also extend to our commitment to a safe and healthy work environment for our employees.

Boston Valley Terra Cotta strives to be the most internationally recognized and diversified manufacturer in architectural ceramics. Whether providing historic restoration units or product for the most innovative designs in new construction, Boston Valley Terra Cotta will maintain the highest standards in quality for both our products and services.

PRODUCT INTRODUCTION

Terra Cotta Products

Family owned and operated, Boston Valley Terra Cotta understands the legacy of terra cotta design, manufacturing and construction. It is because of the design and construction industry's appreciation of this legacy, as well as the industry's knowledge of the properties of terra cotta which make it a superb building material that so much time and effort is spent on restoring terra cotta façades.



Terra Cotta Properties

Formed of clays and other raw materials mined from the earth which are then fired to high temperatures forming permanent bonds, terra cotta has the following properties:

- Non-Combustible
- Resistant to UV fade
- Does not off-gas
- Inherent color range
- High compressive strength
- Plasticity to be formed into various shapes and profiles
- Ability to withstand severe climates and with proper installation and maintenance can be expected to serve a building for hundreds of years

At our manufacturing facility in Orchard Park, New York, clays from the largest mining operations in North America are blended according to specific recipes that have been engineered to meet industry standards in tolerance and performance criteria. BVTC works with industry professionals as we refine our product and our manufacturing methods to ensure that we are delivering the highest quality terra cotta to our clients. For a list of industry standards and testing, visit our website at www.bostonvalley.com or turn to the Performance Section of this booklet.



A skilled sculptor puts the finishing touches on a Corinthian capital for P.S. 114 in New York City.

Lead Times of Terra Cotta

Architectural terra cotta is a natural material fired to 2100 degrees fahrenheit over a number of days. The batching, souring, forming, drying, firing, glazing, sizing, fitting and quality inspection processes take time. Technological advances and ceramic engineering continually raise the level of quality and performance; however, they cannot change all of the time requirements of this ancient material.

Lead times vary from project to project. Projects requiring only a few replacement units may receive product 6 to 8 weeks from all approvals where as a large, full-façade restoration may take 18 to 24 months before the project is complete.



An enormous finial for the Life Sciences Secondary School in Manhattan is sculpted to replicate the original from the early 20th Century.

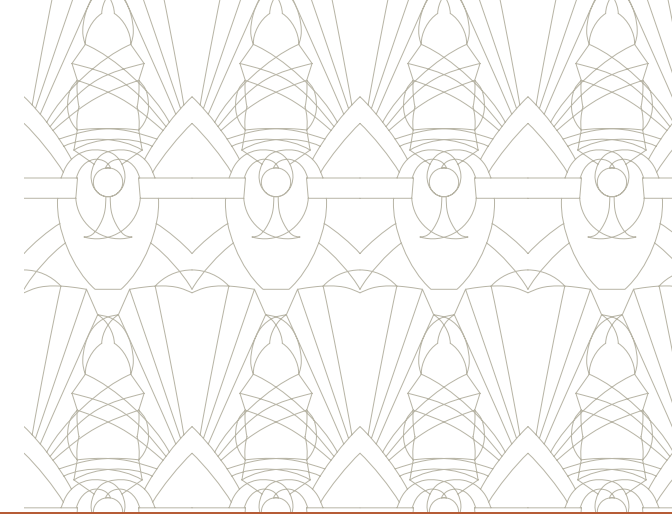

PROJECT INSTALLATIONS: RESTORATION

Terra Cotta Restoration | 12

Project Installations | 14

FLUSHING HIGH SCHOOL

UTAH STATE CAPITOL

*FREDERIC H. PEASE AUDITORIUM, EASTERN
MICHIGAN UNIVERSITY*

STOECKEL HALL, YALE UNIVERSITY

DETROIT PUBLIC LIBRARY

90 WEST STREET

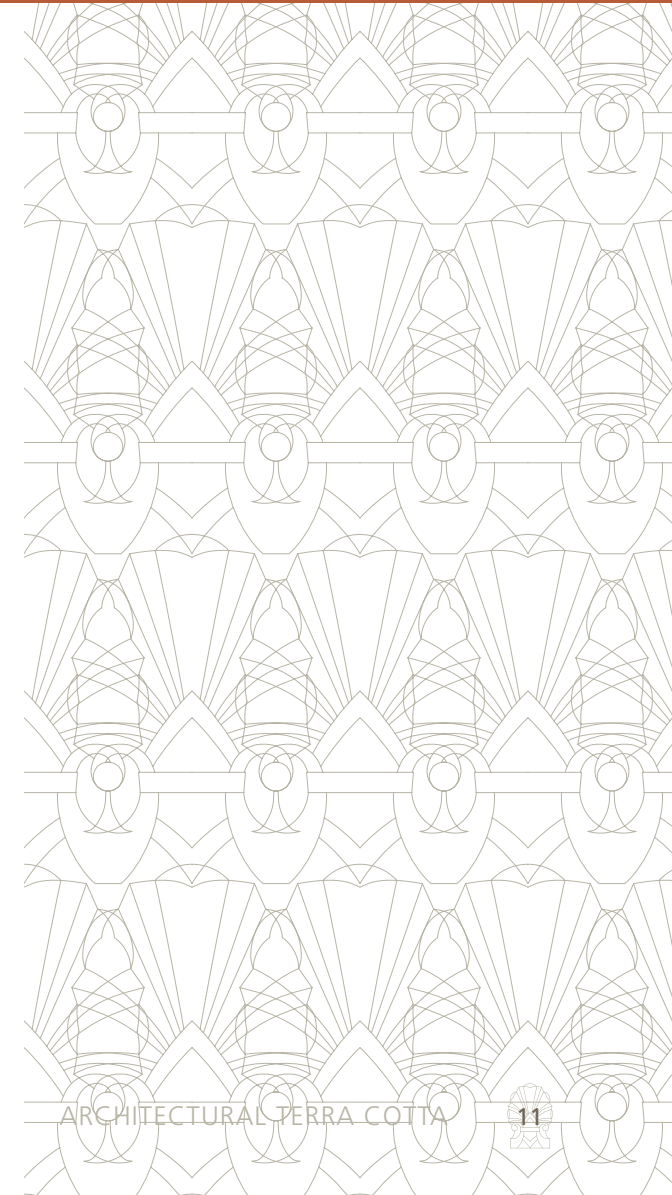



LEFT: Boston Valley created restoration pieces for Cass Gilbert's 90 West St. façade that were damaged during the September 11th attacks.



TERRA COTTA RESTORATION

Boston Valley Terra Cotta's products specified for historic restoration have contributed to the successful preservation of some of the most architecturally significant buildings in the United States, Canada, and abroad. Terra cotta units crafted at BVTVC to replace pieces that had been in service, often for 100 years, can be seen on buildings in cities from New York to New Orleans, Chicago, San Antonio, and San Francisco.



Below is a short list of several of the architecturally significant buildings for which BVTVC has provided terra cotta restoration products.

US Post Office & Courthouse
Brooklyn, NY
ARCHITECT: James A. Wetmore

Reliance Building
Chicago, IL
ARCHITECT: D.H.Burnham & Company

90 West Street
New York, NY
ARCHITECT: Cass Gilbert

Rookery
Chicago, IL
ARCHITECT: Burnham & Root

City College of New York
New York, NY
ARCHITECT: George Post

James Farley Post Office
New York, NY
ARCHITECT: McKim, Mead, & White

65 Bleeker Street
New York, NY
ARCHITECT: Adler & Sullivan

Los Angeles City Hall
Los Angeles, CA
ARCHITECT: Parkinson, Austin, Martin

Fisher Building
Chicago, IL
ARCHITECT: D.H.Burnham & Company

Russ Building
San Francisco, CA
ARCHITECT: George W. Kelham



©Brett Drury Architectural Photography, Inc.

PROJECT INSTALLATIONS

Flushing High School

Flushing, NY
 RESTORATION ARCHITECT School Construction Authority
 INSTALLATION CONTRACTOR Adam's European

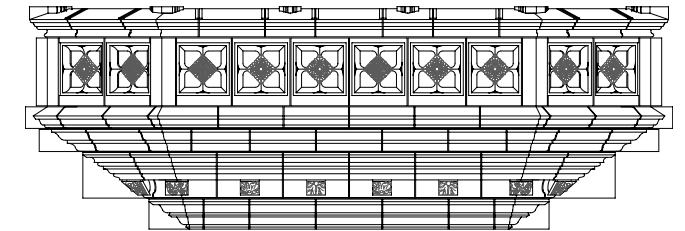
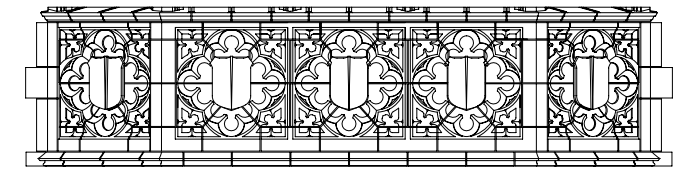
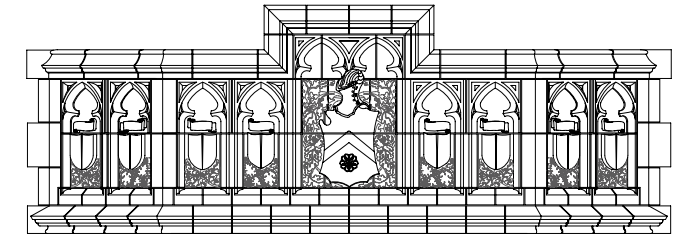

2 PARTIAL ELEVATION

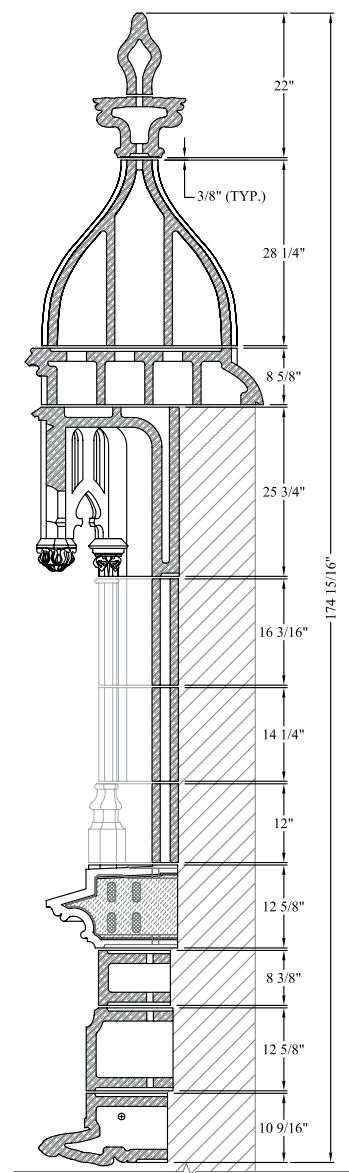

1 SECTION AT TABERNACLE

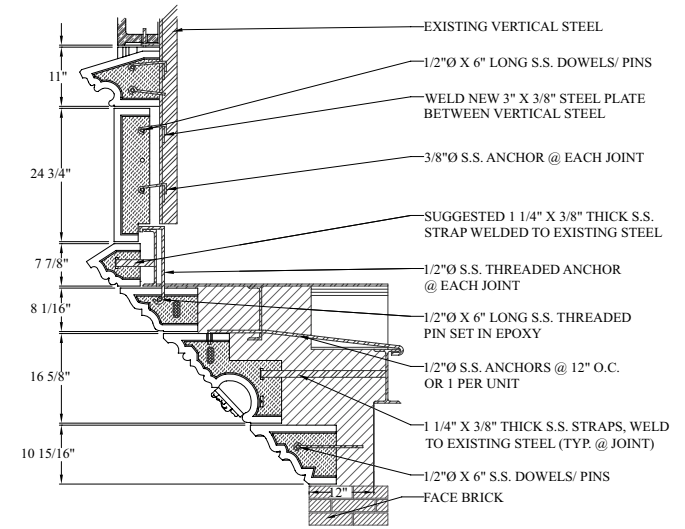

3 SECTION AT LOWER BAY WINDOW

PROJECT INSTALLATIONS

Utah State Capitol

Salt Lake City, UT

RESTORATION ARCHITECT MJSA Architects

ARCHITECT OF THE CAPITOL David Hart

INSTALLATION CONTRACTOR KEPCO+

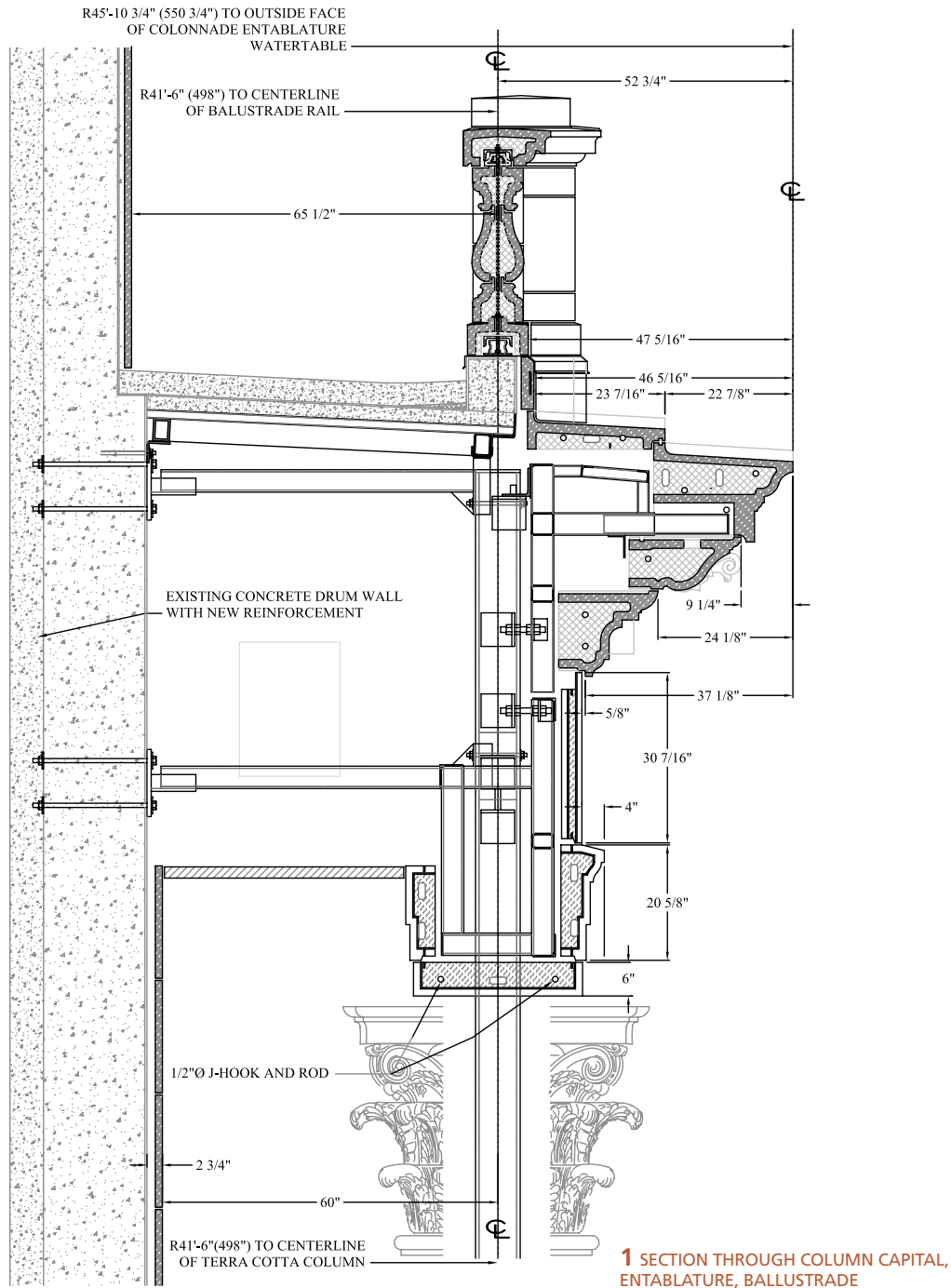

PROJECT INSTALLATIONS

**Frederic H. Pease Auditorium,
Eastern Michigan University**

Ypsilanti, MI

RESTORATION ARCHITECT Quinn Evans Architects
INSTALLATION CONTRACTOR Grunwell-Cashero Co.

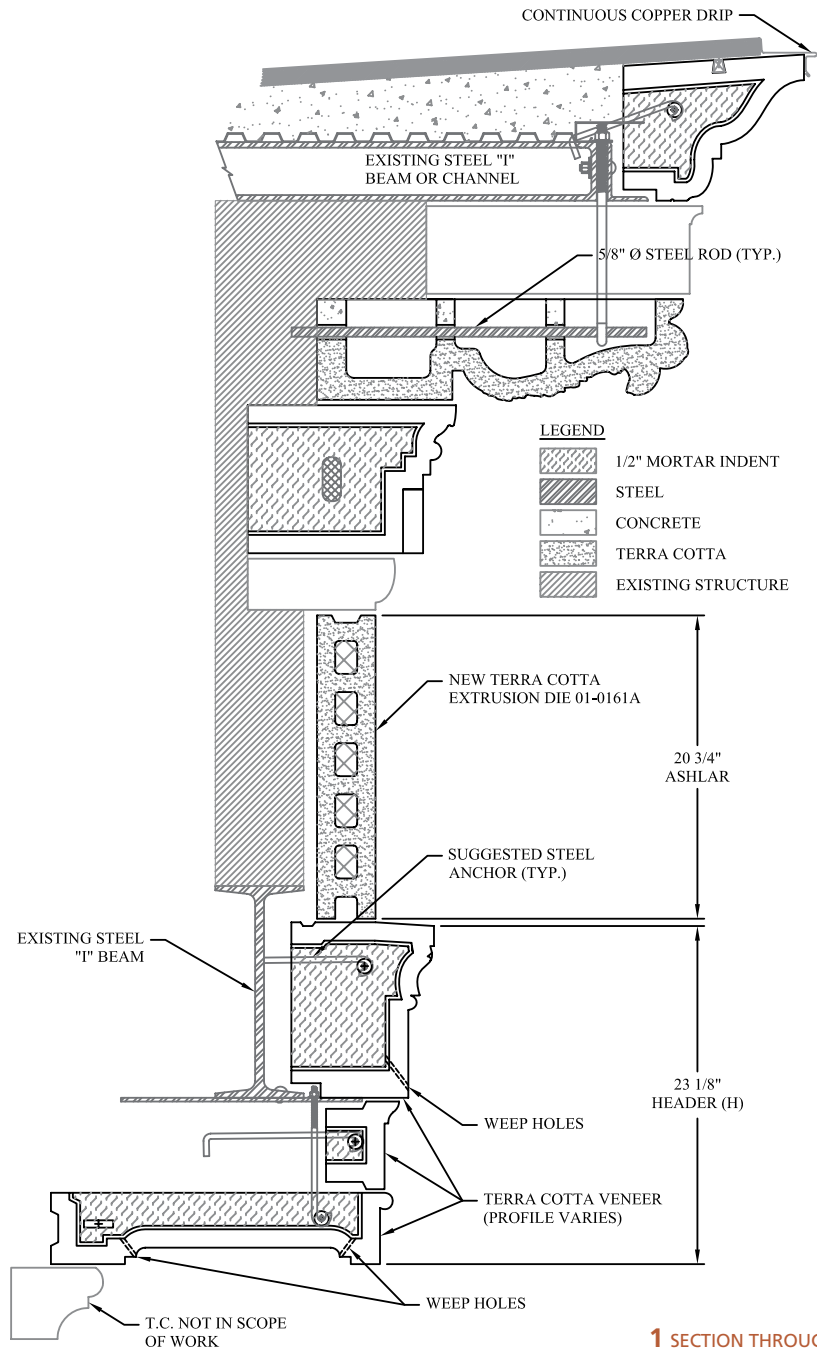

1 SECTION THROUGH ENTABLATURE

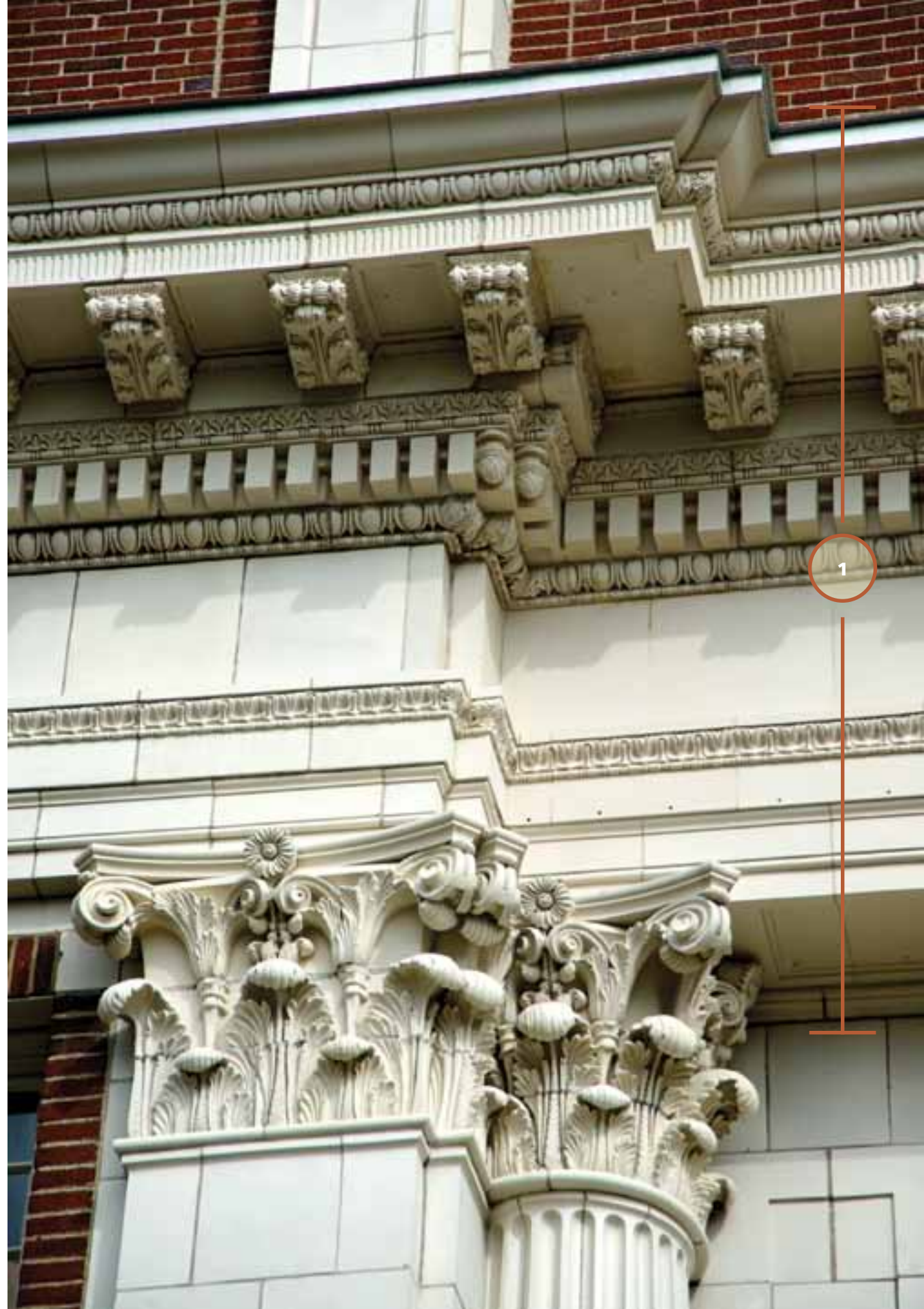



PROJECT INSTALLATIONS

Stoeckel Hall, Yale University

New Haven, CT

RESTORATION ARCHITECT Charney Architects LLC

INSTALLATION CONTRACTOR G.L. Capasso, Inc.

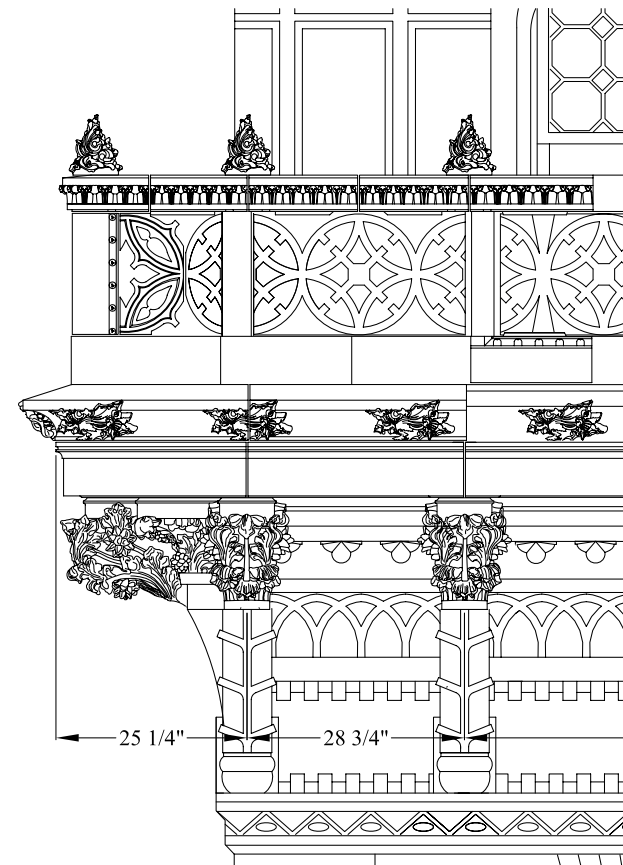

1 ELEVATION DETAIL

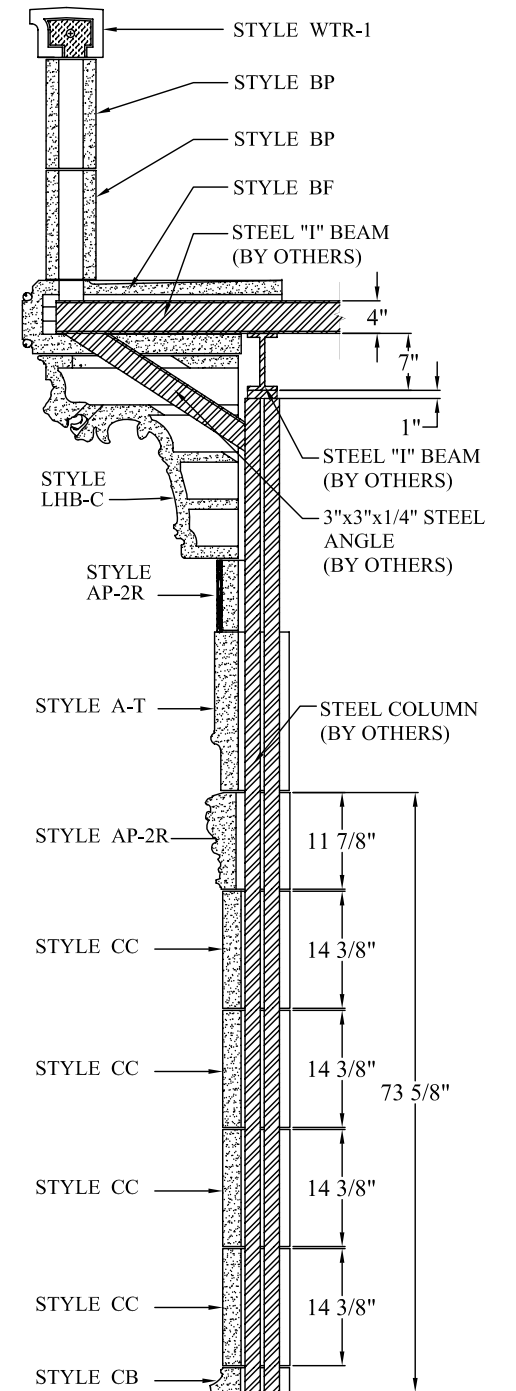

2 SECTION THROUGH BALCONY

PROJECT INSTALLATIONS

Detroit Public Library

Detroit, MI

RESTORATION ARCHITECT Hamilton Anderson Associates

INSTALLATION CONTRACTOR Grunwell-Cashero Co.

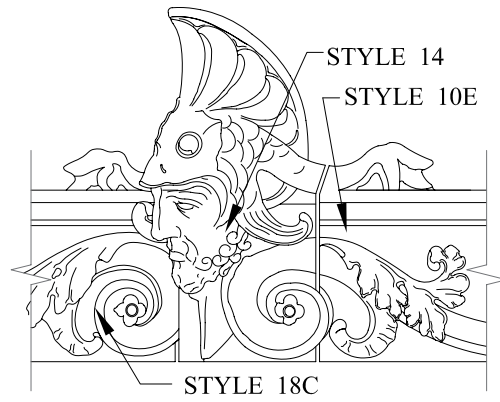

1 ELEVATION DETAIL

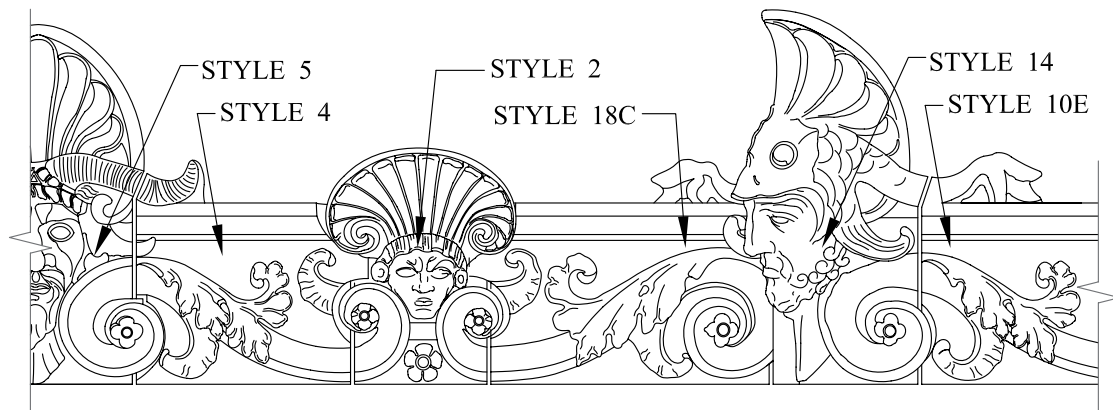

2 ELEVATION DETAIL

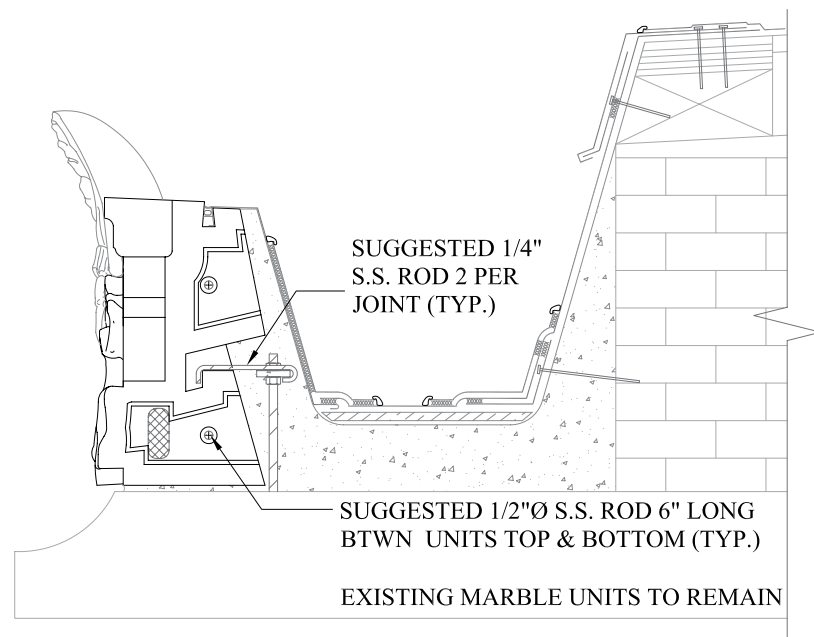

3 SECTION THROUGH PARAPET



PROJECT INSTALLATIONS

90 West Street

New York, NY

RESTORATION ENGINEER Façade Maintenance Design

RESTORATION ARCHITECT H. Thomas O'Hara Architect

INSTALLATION CONTRACTOR Seaboard

Weatherproofing Co.

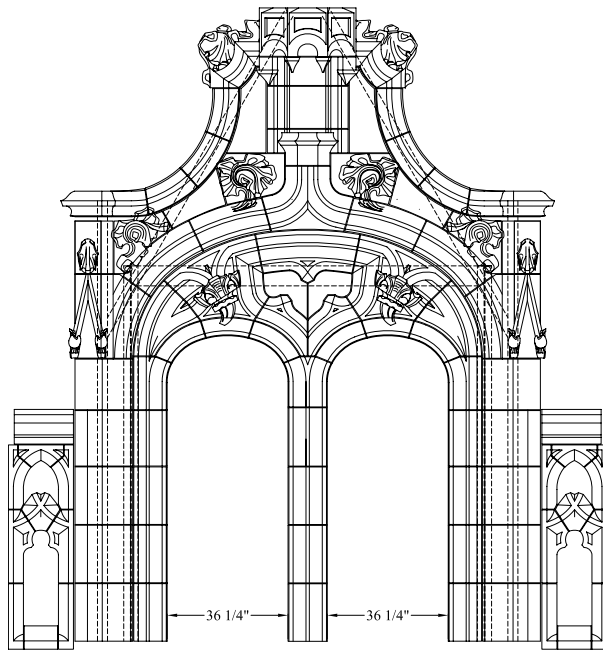

1 LARGE DORMER ASSEMBLY ELEVATION

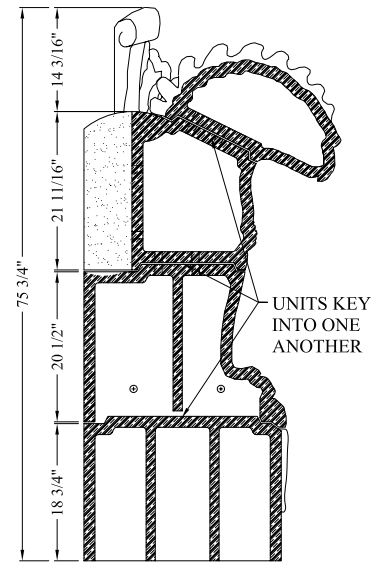

3 GARGOYLE SECTION

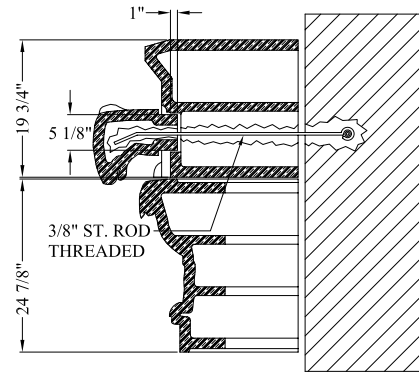

4 COLUMN CAPITAL SECTION

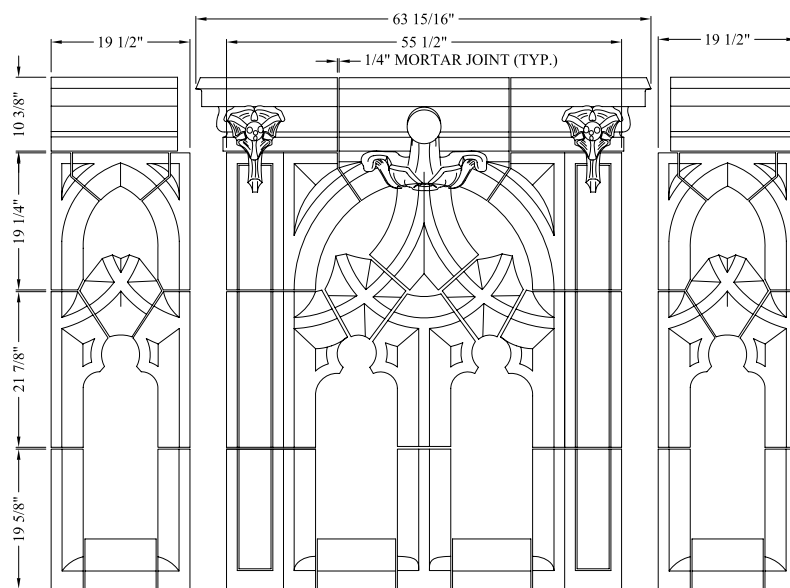

2 SMALL DORMER ASSEMBLY ELEVATION

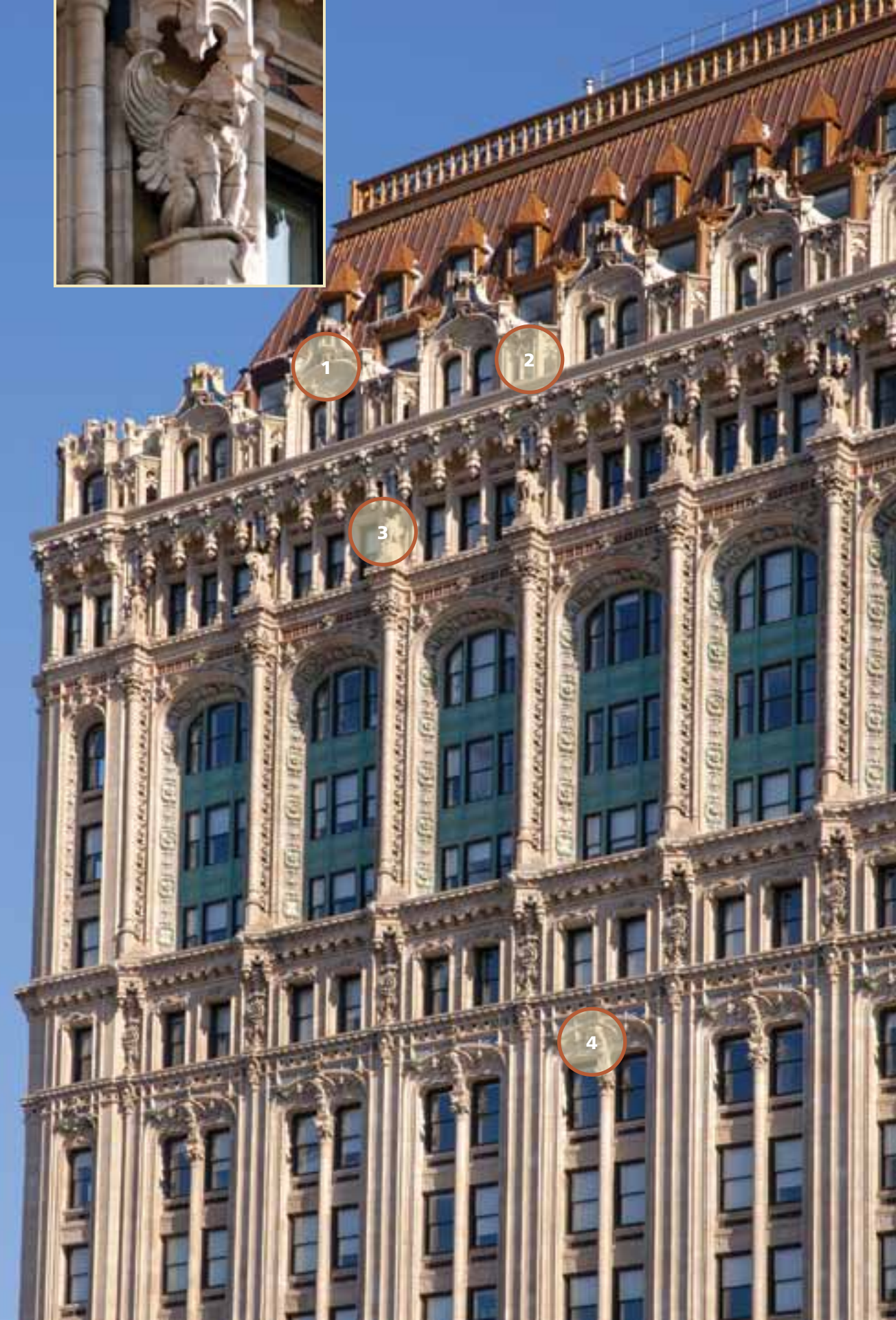

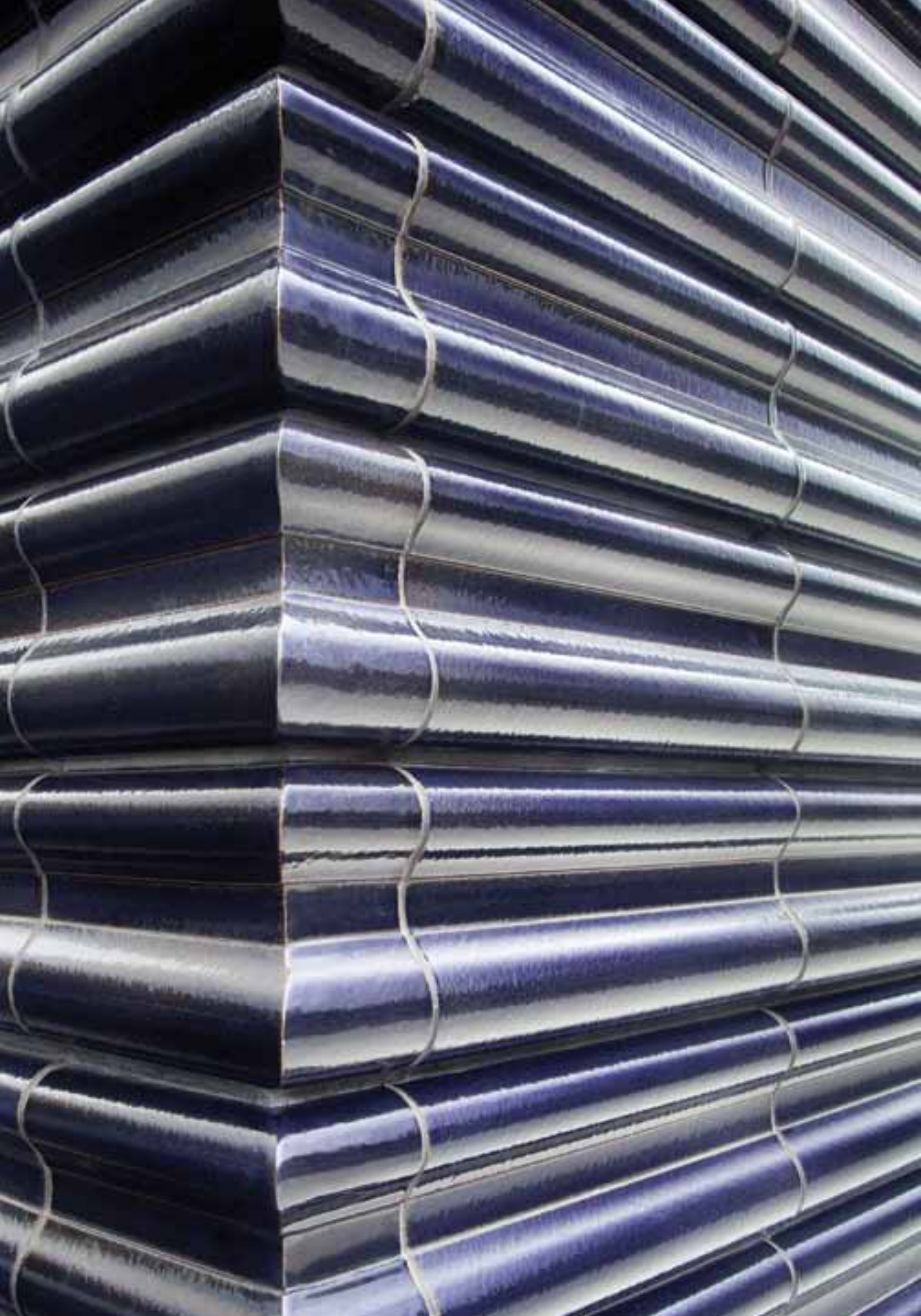

Boston Valley worked with Annabelle Selldorf to create this custom extrusion profile for her project at 520 West Chelsea.

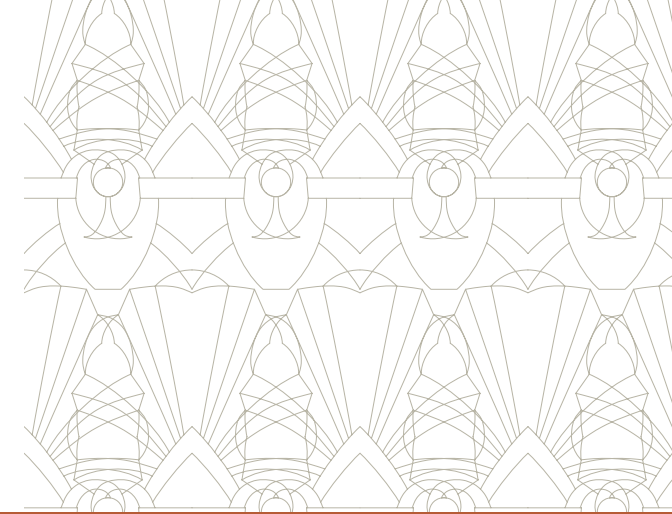

PROJECT INSTALLATIONS: NEW CONSTRUCTION

Terra Cotta New Construction | 28

Project Installations | 30

OLD PLANK TRAIL COMMUNITY BANK

520 WEST CHELSEA

200 ELEVENTH AVENUE

HEARST TOWER PLAZA

WEST LAFAYETTE PUBLIC LIBRARY

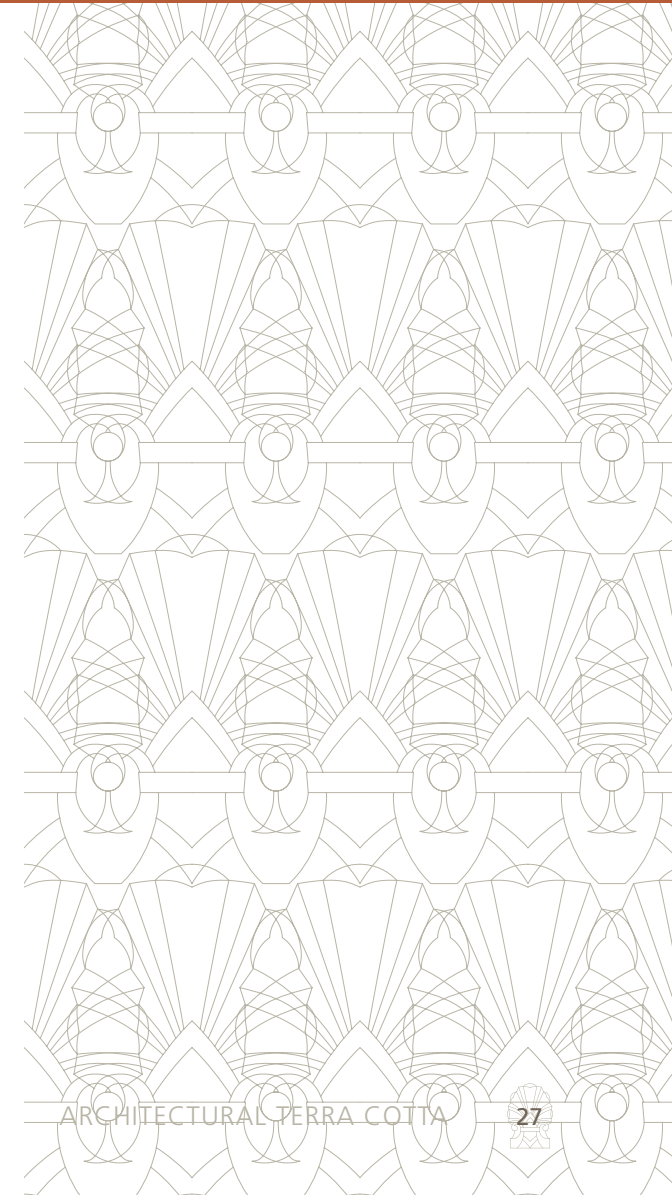



Few products have come to surpass terra cotta in longevity, aesthetics and sustainability.

TERRA COTTA NEW CONSTRUCTION

While many new products for cladding a façade have been introduced to the construction industry in the years since terra cotta had its hey-day, few have come to surpass terra cotta in longevity, aesthetics and sustainability. Terra cotta continues to be a material of choice for many designers because of its malleability with regard to shape and texture, its abundance of finish options, its compatibility with other building products, as well as its ability to withstand severe climates both for freeze-thaw and UV resistance.

Throughout our 30 years of manufacturing terra cotta, Boston Valley Terra Cotta has taken advantage of various technological advances and introduced these into our manufacturing process. With the inclusion of extrusion as one of our forming methods, BVTC has amassed a library of over 600 extrusion dies. The hardened steel dies are property of Boston Valley Terra Cotta and can therefore be utilized by architects for new masonry construction. Our library includes multiple styles for ashlar, quoins, copings, sills and cornices among other architectural block styles, so whether you need an accent band to compliment a brick structure, or you are designing a complete terra cotta façade, BVTC has an extrusion die to fit your needs.

This section of the booklet presents several new masonry construction projects for which BVTC provided terra cotta products. All but one of the projects utilized extrusion dies and the final utilized RAM press technology. These projects demonstrate how seamlessly terra cotta can be integrated into a building façade and why terra cotta is still such a valuable building product for new construction.



PROJECT INSTALLATIONS

Old Plank Trail Community Bank

Mokena, IL

ARCHITECT Grund & Riesterer Architects

INSTALLATION CONTRACTOR Illinois Masonry Corp.

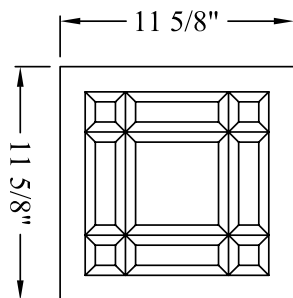

1 ELEVATION DETAIL - RAM PRESS UNIT

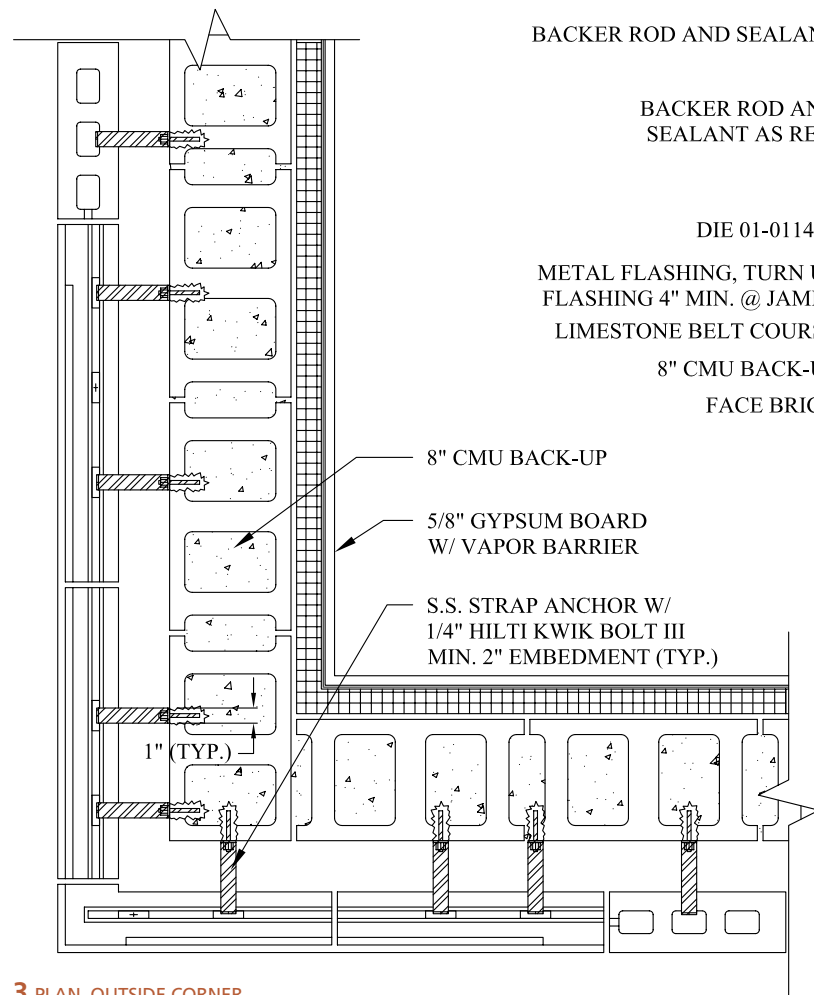

3 PLAN, OUTSIDE CORNER

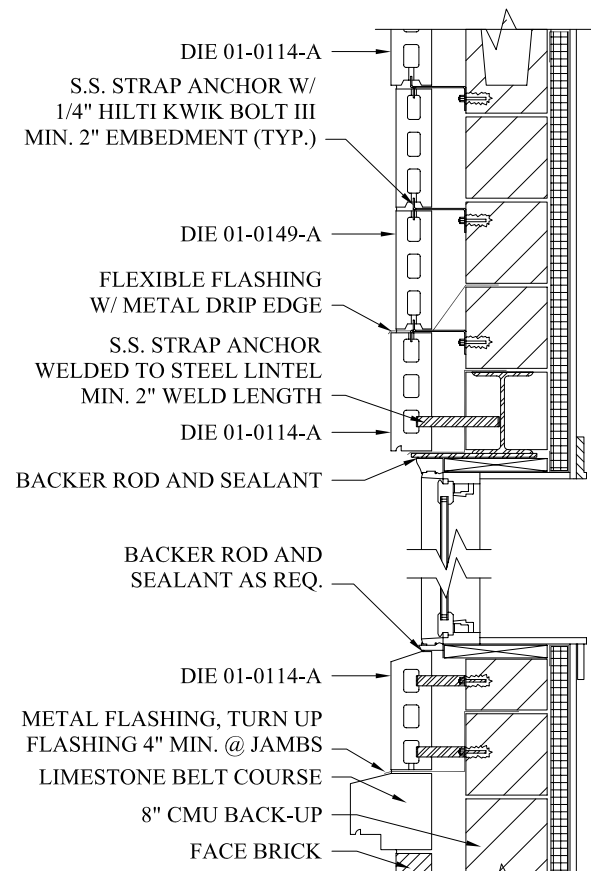

2 SECTION

- DIE 01-0114-A
- S.S. STRAP ANCHOR W/
1/4" HILTI KWIK BOLT III
MIN. 2" EMBEDMENT (TYP.)
- DIE 01-0149-A
- FLEXIBLE FLASHING
W/ METAL DRIP EDGE
- S.S. STRAP ANCHOR
WELDED TO STEEL LINTEL
MIN. 2" WELD LENGTH
- DIE 01-0114-A
- BACKER ROD AND SEALANT
- BACKER ROD AND
SEALANT AS REQ.
- DIE 01-0114-A
- METAL FLASHING, TURN UP
FLASHING 4" MIN. @ JAMBS
- LIMESTONE BELT COURSE
- 8" CMU BACK-UP
- FACE BRICK
- 8" CMU BACK-UP
- 5/8" GYPSUM BOARD
W/ VAPOR BARRIER
- S.S. STRAP ANCHOR W/
1/4" HILTI KWIK BOLT III
MIN. 2" EMBEDMENT (TYP.)
- 1" (TYP.)



520 West Chelsea

New York, NY

ARCHITECT Selldorf Architects

INSTALLATION CONTRACTOR Graciano Corp.

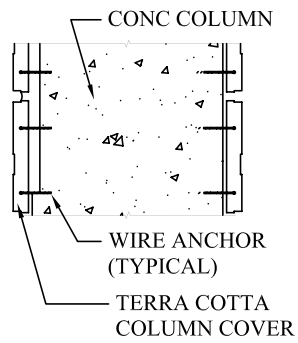

2 COLUMN SECTION

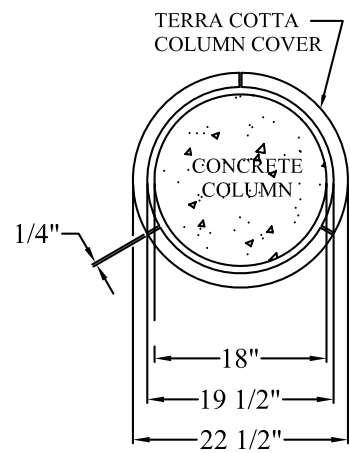

2 COLUMN PLAN

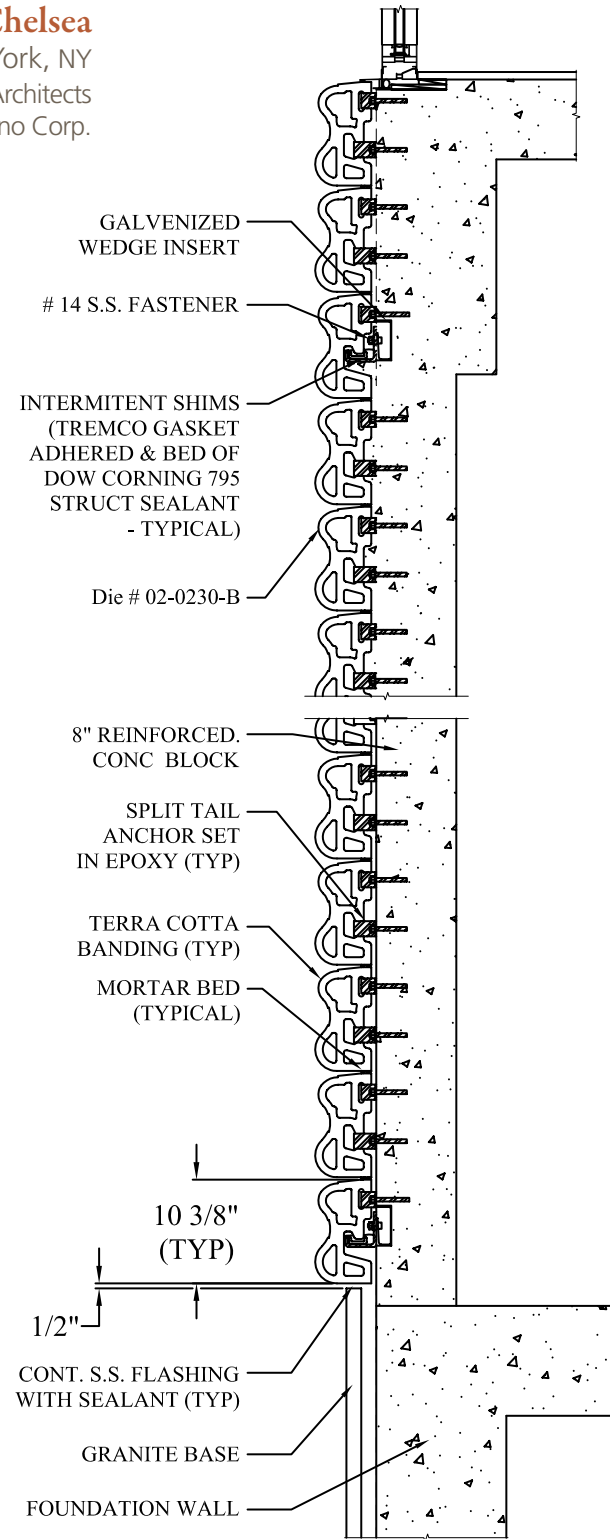

1 SECTION THROUGH WALL



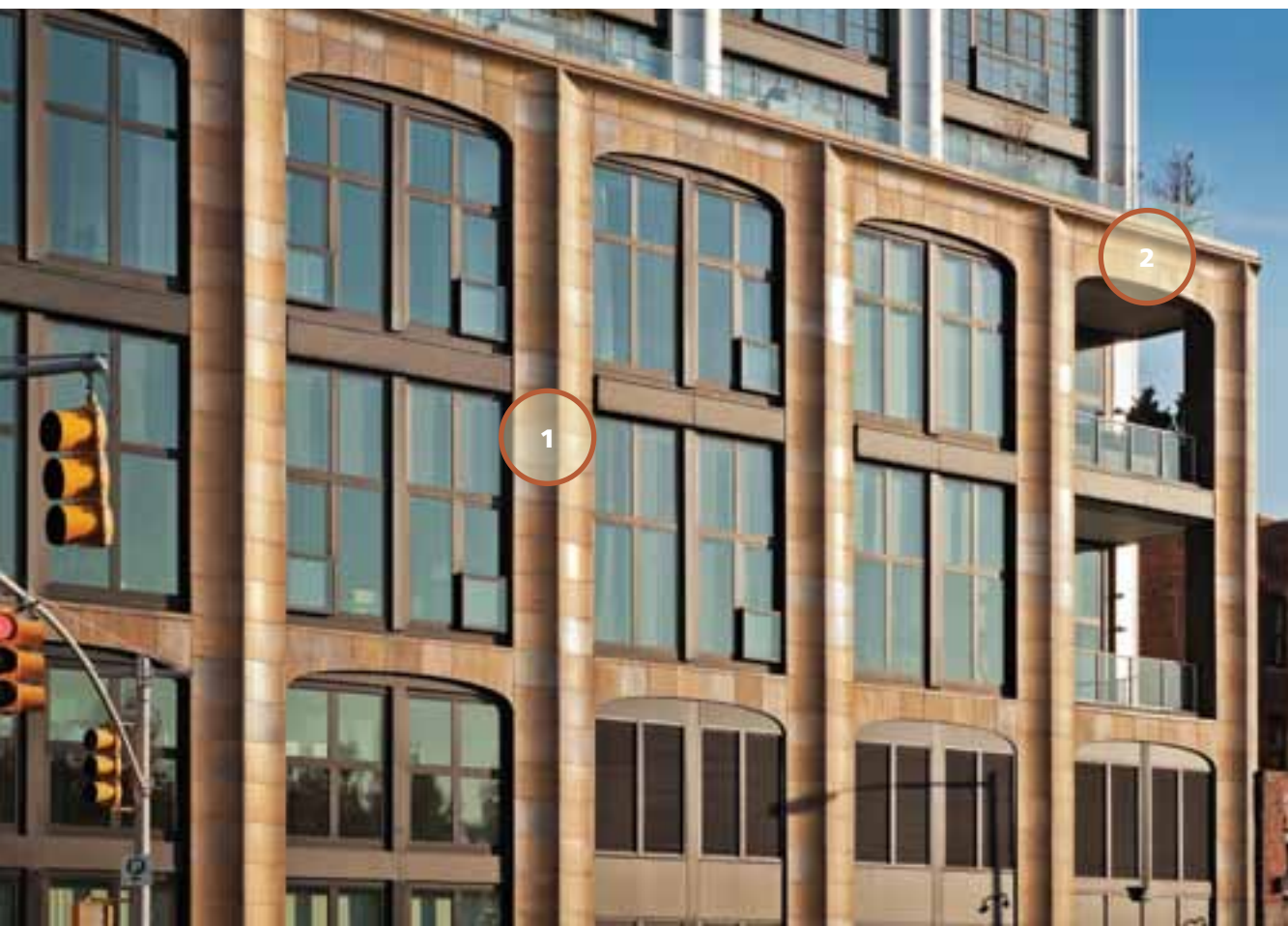

PROJECT INSTALLATIONS

200 Eleventh Avenue

New York, NY

DESIGN ARCHITECT Selldorf Architects

ARCHITECT OF RECORD Steven Kratchman
Architect, D.C.

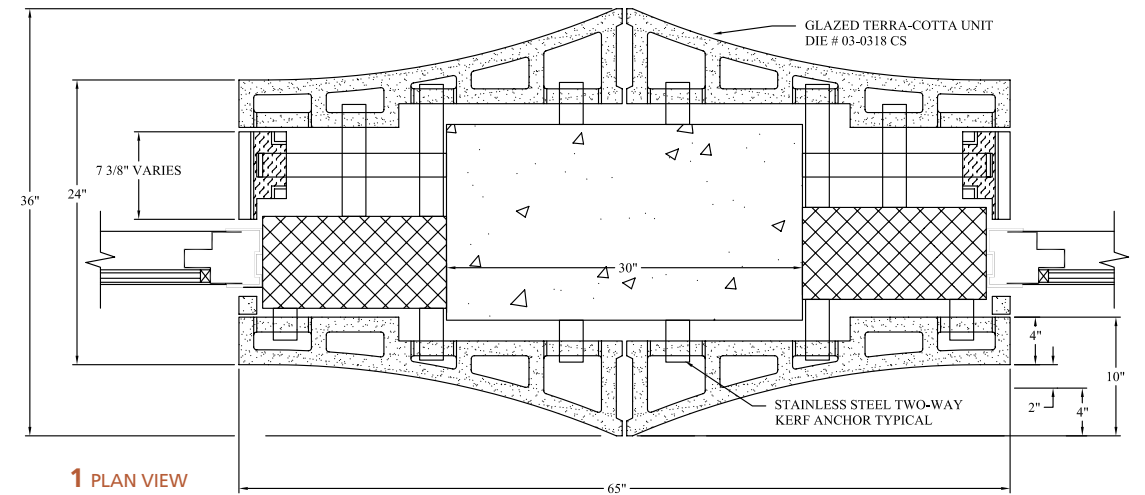

1 PLAN VIEW

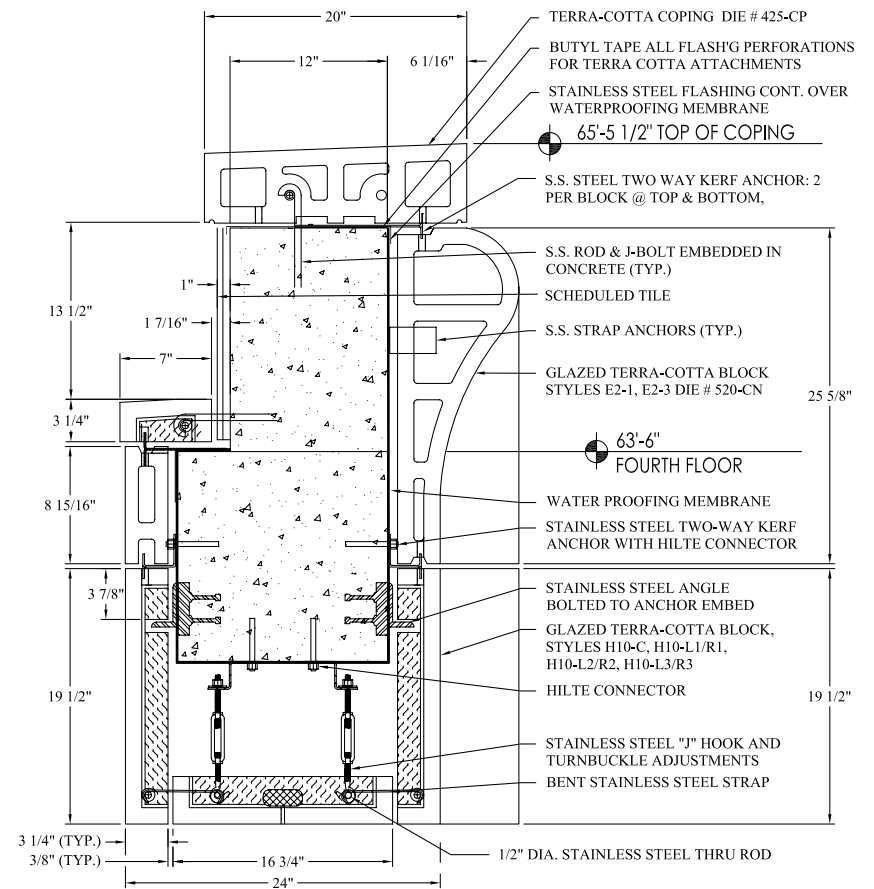

2 SECTION DETAIL

Hearst Tower Plaza

Charlotte, NC

INSTALLATION CONTRACTOR Shelco, Inc.

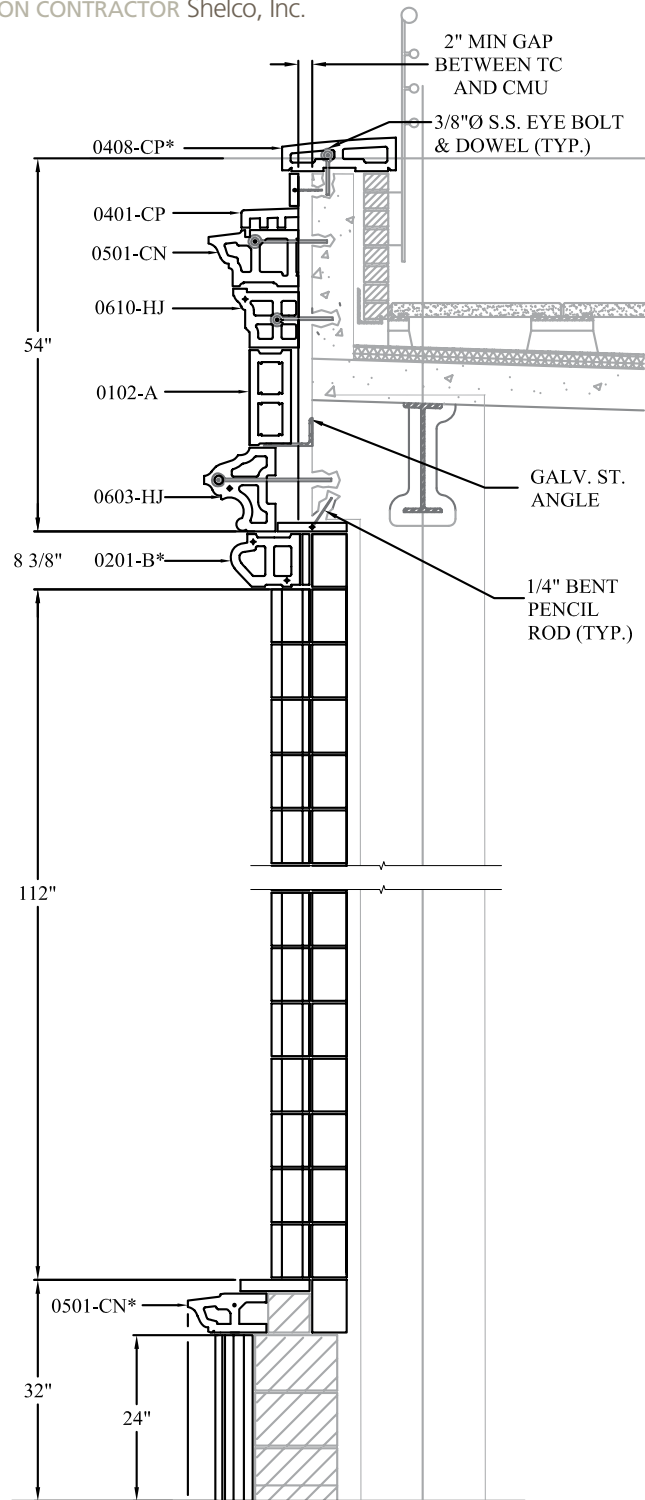

1 SECTION



PROJECT INSTALLATIONS

West Lafayette Public Library

West Lafayette, IN

ARCHITECT krM Architecture +

INSTALLATION CONTRACTOR Bronger Masonry, Inc.

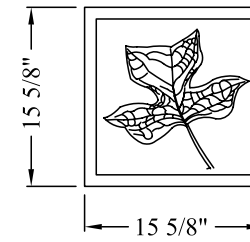

**MEDALLION
(TULIPTREE)**

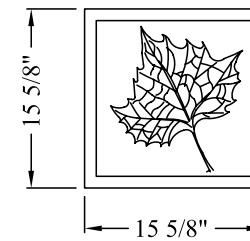

**MEDALLION
(SYCAMORE)**

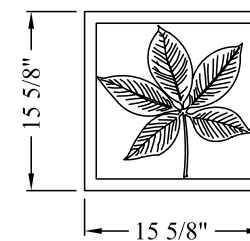

**MEDALLION
(OHIO BUCKEYE)**

1 DETAIL ELEVATIONS - RAM PRESSED UNITS

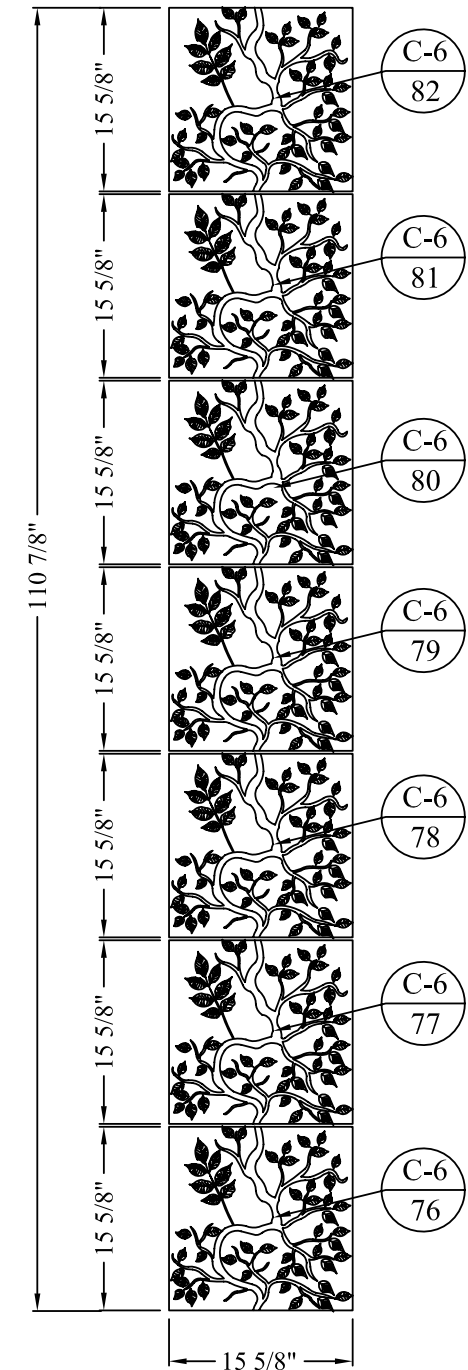

2 COLUMN ELEVATION - RAM PRESSED UNITS



Finial unit recently released from mold awaiting finishing by one of Boston Valley's skilled artisans.
(Finished unit shown on page 51.)

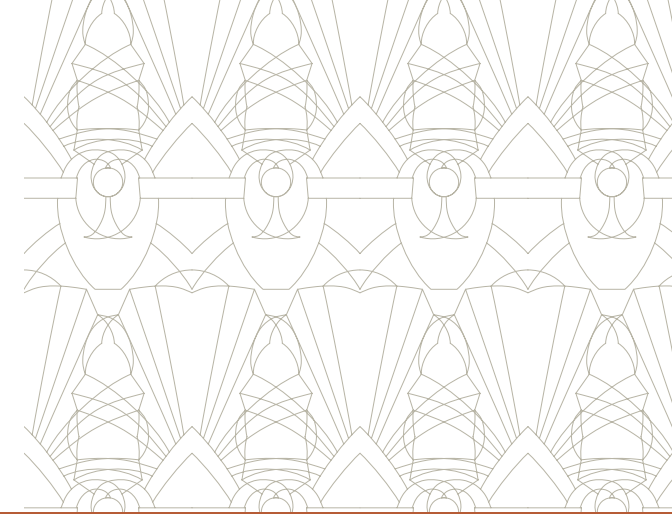

TERRA COTTA MANUFACTURING PROCESS

Our Manufacturing Process | 42

PREPRODUCTION

PRODUCTION

QUALITY CONTROL

TECHNOLOGY & INNOVATION

Color & Finish Options | 60

CUSTOM CLAY BODY COLOR

COLOR RANGE

GLAZE FINISHES

TEXTURE

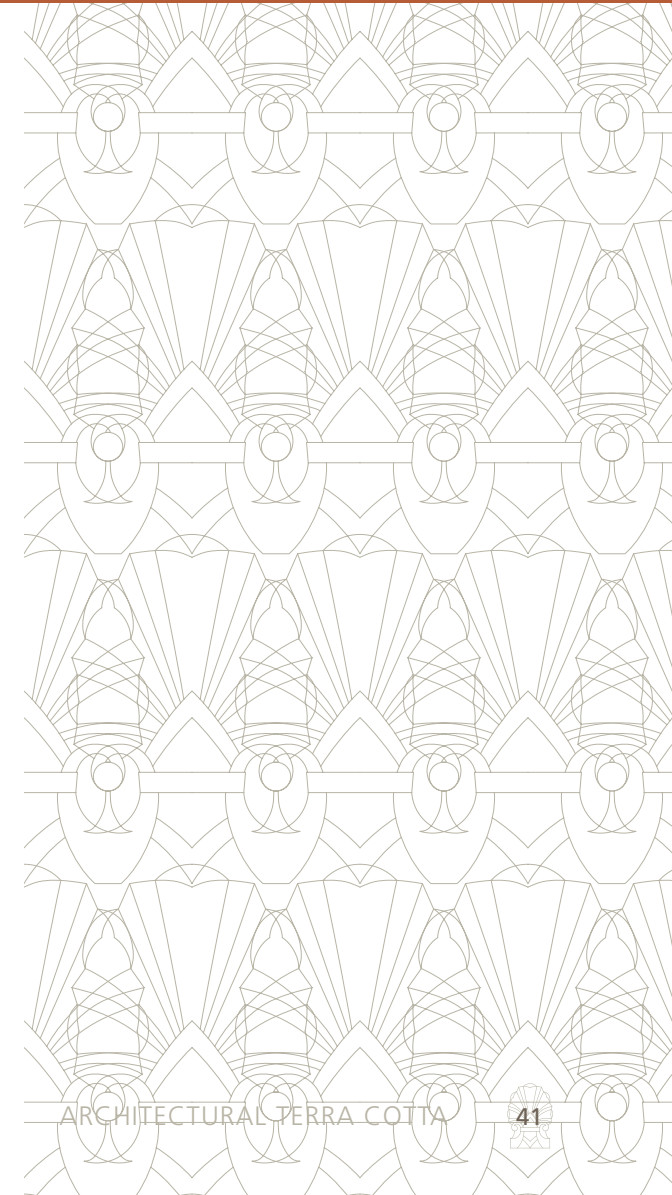



OUR MANUFACTURING PROCESS

Terra cotta is an ancient material that has been used to construct buildings for thousands of years. Boston Valley Terra Cotta's success has been generated not only through our understanding of the material itself, but also through our awareness of historic means of manufacturing versus contemporary means of manufacturing and technological innovations. Both classical and contemporary manufacturing methods have a place in our facility. This is represented in our use of plaster for hand-press molds versus our use of CNC machine tooled steel dies for extrusion technology, or our use of skilled craftspeople to carve the details into restoration units versus our use of overhead lifting devices to move the units around our facility.

As a market leader, BVTC is constantly monitoring the building products industry for advances in design as they relate to the needs of the architectural community, and investing in technological advances in manufacturing means and methods. We have implemented use of bar code scanners to track product through our facility and calculate production rates. BVTC has formed partnerships with local universities to provide experience based opportunities for the next generation of design professionals and infuse Boston Valley with cutting edge knowledge and ideas. Through these collaborations and advances in technology, we continually advance terra cotta opportunities for the design and construction markets.

Over the last 30 years, BVTC has invested \$16 million in capital improvements. This has given us a competitive edge by assuring that we produce materials of the highest quality with on time delivery. The manufacture of terra cotta is a process with specific stages, needs and time constraints. BVTC strives to help our clients understand this process by maintaining an open dialogue throughout production to ensure the successful completion of each project.



Preproduction

Site Survey & Drafting

After a restoration project has been activated at BVTC, the first step in the process is the site survey. A survey team will tag, photograph and document the samples required for reproduction according to the contract scope. The samples then need to be sent by the contractor to BVTC's facility where they will be catalogued and drawn electronically as individual units, in both setting elevations and section details. Project specific anchoring details are provided by the project architect/engineer. Each individual unit will be given a block style name, number and unit number that will be associated with them throughout production. New construction projects, while not requiring site survey, do require the full set of architectural and structural drawings for shop, setting and section drawings to be created. For both restoration and new construction, BVTC requires written approval of all drawings prior to the start of production.





With thousands of colors in our glaze library, we have a history of successful glaze development to draw upon.

Glaze & Clay Body Research & Development

Color development typically occurs concurrently to the work of the drafting department. R&D for glaze matching and/or clay body development on a restoration project requires selection of a 12"x12" or larger control sample by the architect or building owner. This control sample must be cleaned with the same solution that will be used to clean the building. A new construction project can draw upon past BVTC projects and other materials including paint colors, Pantone colors, fabric swatches, or other façade materials as a basis to start discussions about the glaze finish or clay body color.



Once BVTC has received this control sample, we will begin working with our in house glaze recipes, minerals and stains to achieve an acceptable match to the glaze finish or custom clay body color. A 6" x 6" sample tile will be created for each test. Half of this tile will be sent to the individual who selected the control sample while the other half is retained for BVTC's record. Should any modifications be requested, BVTC will perform additional tests; should the tile be found acceptable, BVTC will require a written record of approval. With hundreds of colors in our glaze library, BVTC's R&D Department has a history of successful glaze development to draw upon for your restoration or new construction project.



Model & Mold Shop

Upon approval of glaze/clay body color and all drawings, most projects proceed to the model and mold shop. This department uses the shop drawings created for each individual restoration piece to produce a model of the unit. Because clay is formed wet but goes through a drying and firing process, the model must be made approximately 8% larger in all dimensions than the finished unit to account for the shrinkage that will occur. The model and mold shop uses different material such as plaster, Plasticine®, rubber, wood and metal in their crafting of the model. Once the model has been approved, either by our in-house Q.C. process or a visiting project team, a 5 piece mold will be taken of the model. The number of units required for each block style determines how many molds are needed to complete the job. Once made, the molds are dried and then sent on to production. This department makes molds for use primarily in the hand pressing production of units but also for the RAM press and slip casting operations.



Production

Batching

Raw materials for our clay recipes are delivered to Boston Valley in dry powder form in supersacks weighing 2200 lbs. BVTC sources all the clays used from North America and blends 2–3 clays in each recipe. Each recipe is dry batched according to the current formula by a computer-controlled cart that is calibrated quarterly. After the proper amount of each ingredient is weighed out, the batch is placed in a muller-mixer where it is first dry blended, and then the proper amount of water is added and the batch is thoroughly blended. This mixture is dumped into a souring bin where it is allowed to age for at least 24 hours before use so that the water has time to hydrate the raw materials at a molecular level to increase the plasticity of the clay. Once aged, the clay is extruded into a slug for use in the hand pressing or RAM pressing operation or extruded through a steel die into a specific profile.



Production Forming Methods

Boston Valley Terra Cotta employs four forming methods in the production of our architectural terra cotta. These forming methods, discussed below, are used to create through-body as well as glazed terra cotta units for masonry construction. The quantity, amount of sculptural detail, profile and size determine if a unit is hand pressed, RAM pressed, extruded or slip cast.



Hand Press

This forming method is used for sculptural pieces, particularly ones that contain non-linear detailing or details with undercuts. The molds that are the negative of the finished piece are filled by hand with malleable clay. Rubber mallets are used to press the clay against all five faces of the mold to a set thickness. Internal webs are formed according to approved shop drawings and provide stability for the walls during drying and firing. Once pressed, the piece sits for a period. The plaster dehydrates the clay, allowing the piece to hold its form when released from the mold.



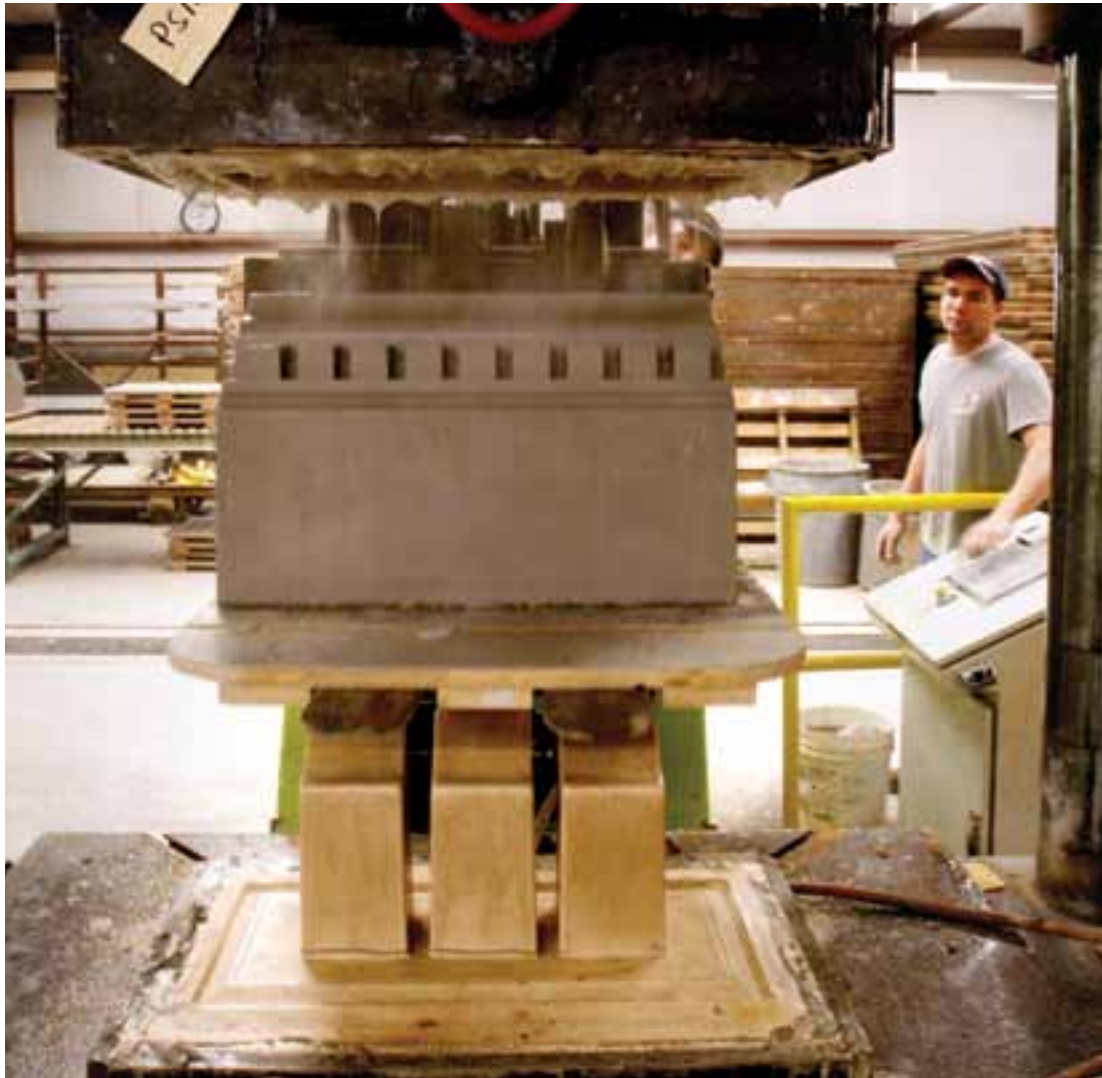

RAM Press

The RAM press is a hydraulic press originally used as a forming method in the porcelain industry. Pieces made with this forming method are not generally as sculptural as those made by hand pressing, however like hand pressing, this forming method does not allow for undercuts to be included in the die. The RAM die is a two part die made at BVTC to the approved shop drawing in the model and mold shop. A clay slug is placed on the die and hydraulically pressed into the form. Air forces water in the plaster die to the surface, releasing the piece from the mold.



Extrusion

The extrusion forming method is most useful for the production of a linear directional profile that requires many units. This method of production utilizes a large extruder to force the clay through a steel die, forming a hollow cored unit. The profiles are extruded into lengths longer than the finished size required to account for the shrinkage during drying and firing. They are rough cut with a wire and sent on to the finishing department. BVTC has amassed a large catalogue of extrusion dies that can be used for new construction masonry projects.





Slip Cast

Slip casting utilizes a special recipe that produces a liquid clay body. This clay body is poured into a plaster mold and allowed to sit for a specified period of time. Again as in hand pressing, the plaster begins the dehydration process, drawing the water out of the liquid clay suspension and causing a measurable quantity of the solids to build up on the sides of the mold. Once the desired wall thickness of the finished piece is achieved, the extra liquid clay body is evacuated from the mold, and the piece is allowed to dry further before being released from the mold. This forming method is particularly suited for pieces with fine ornamentation and units that need to be hollow for anchoring such as balusters.



Finishing

All units, no matter their forming method, pass through the finishing department and the hands of a BVTC sculptor. For units that have been made using the hand press, RAM press or slip casting methods, the finishing process first involves smoothing out the rough spots and edges that exist after the piece is released from the mold, as well as removing any of the undercuts that cannot be formed directly out of the mold. All units, including those that are extruded, have anchor slots and mortar indents carved out according to the approved shop drawing. Their block style and number are stamped into the wet clay. Finally, any textures or other ornamentation needed are added in the finishing department so that the new piece replicates the historic sample or approved new construction unit in all aspects of shape and texture.



Drying & Glaze Application

Upon the units' completion in the finishing department, they are loaded into the driers to have approximately 50–60% of the water removed. The driers are temperature and humidity controlled to ensure a proper drying rate and prevent cracking of the units. Drying cycles can last from 4–8 days depending on the size and quantity of units in the drier.

Those projects that have specified a glaze finish are then taken to the glaze application department. Here, the glaze finish that was developed in the R&D department and approved by the client is applied to a warm terra cotta unit. Glaze finishes can be as simple as a coat of a single recipe or as complicated as a pulsachrome finish that may involve three or four different recipes layered together in full, partial or pulsed coats. Some glaze finishes require application onto terra cotta units that have already been fired, known in the ceramics industry as bisque-ware. The glazing department utilizes various application techniques to achieve the range of finished appearances and topographies required to replicate historic glaze finishes or create unique finishes for new construction projects.



A Boston Valley craftsman applies glaze to a terra cotta unit.



Kilns & Sizing

Our facility houses six large, periodic car gas-fired kilns. Because the product for masonry construction can vary in volume from piece to piece and kiln firing to kiln firing, each hearth is custom built by hand to accommodate each project. Kiln firings last from 3–5 days depending on the cycle needed for the product to be vitrified. As with any ceramic product, terra cotta units demonstrate a color range when fired because of the small differences in temperature from the top to bottom and left to right of the kiln. These variations are inherent to this natural material formed of substances mined from the earth. This natural variation adds to the beauty of the finished product. BVTC will discuss the acceptable product range with each project team and work to produce terra cotta units that fit within those specifications.



A laser-aligned, diamond-edged wet gantry saw cuts finished pieces to proper length.

After firing, almost every unit manufactured at BVTC spends time in our sizing department. Masonry units are typically made oversized on their non-finished face sides so that they can be cut to a clean and accurate dimension post-drying and firing. BVTC uses large format, laser-aligned, diamond-edged wet gantry saws to cut blocks to the width or height specified on the approved shop drawings. The scrap generated from this process is recycled with our own pulverizing equipment and put back into the manufacture of additional terra cotta units.

Quality Control

Layout & Fit

Prior to being packed and shipped, units manufactured at BVTC are checked for conformance with industry standard dimensional tolerances and against the approved color control sample. For large restoration and new construction projects, or when requested by the client, BVTC will also perform a layout and dry-fit of the terra cotta units to ensure alignment of the blocks in an assembly according to the approved setting drawing. This last step in our quality control process confirms to the client that the units can be installed when they arrive at the job site. Clients are welcome to visit the facility to inspect the layout and dry-fit; additionally they could consider hiring a third-party company to perform inspection as has been done for the United States Post Office and Courthouse restoration project. For this three year, 17,000 unit project, BVTC has worked with a third-party company to perform monthly or bi-monthly layout and dry-fit inspections at our facility of every block manufactured for every elevation on the 1930's terra cotta building.

Shipping

The last stop for products before they leave our facility is the shipping department. Here, blocks that have been sized and inspected are packaged into wooden crates. Product is packaged and shipped according to the priority sequencing that was established at the beginning of the project. Each unit number is recorded into a log with the date and crate number indicated, and the contents of every crate are photo documented prior to being shipped. The client will receive a shipping report that provides the project name, date, shipment number, crate number, block style and unit number.



A dry-fit inspection takes place in our facility.

Looking to the future for the next innovation or technology is a key component contributing to Boston Valley's steady growth for more than 30 years.



Technology & Innovation

Looking to the future for the next innovation or technology to benefit terra cotta design and production is a commitment and key component contributing to Boston Valley's steady growth over more than 30 years as a material supplier of architectural terra cotta. Our professional affiliations with industry experts include The Center for Advanced Ceramic Technology (CACT) Alfred University, Architectural Testing Inc. (ATI), University at Buffalo Instrumentation Center and The Center for Industrial Effectiveness (TCIE) a part of the School of Engineering and Applied Sciences to name a few. These technology/testing based affiliations are complimented by several academic collaborations like our most recent Digital Capture and Reproduction initiative with the University at Buffalo School of Architecture. This technological innovation, like so many in the past, contributes positively to product output and quality, ergonomic work conditions, and adherence to specifications and industry standards.

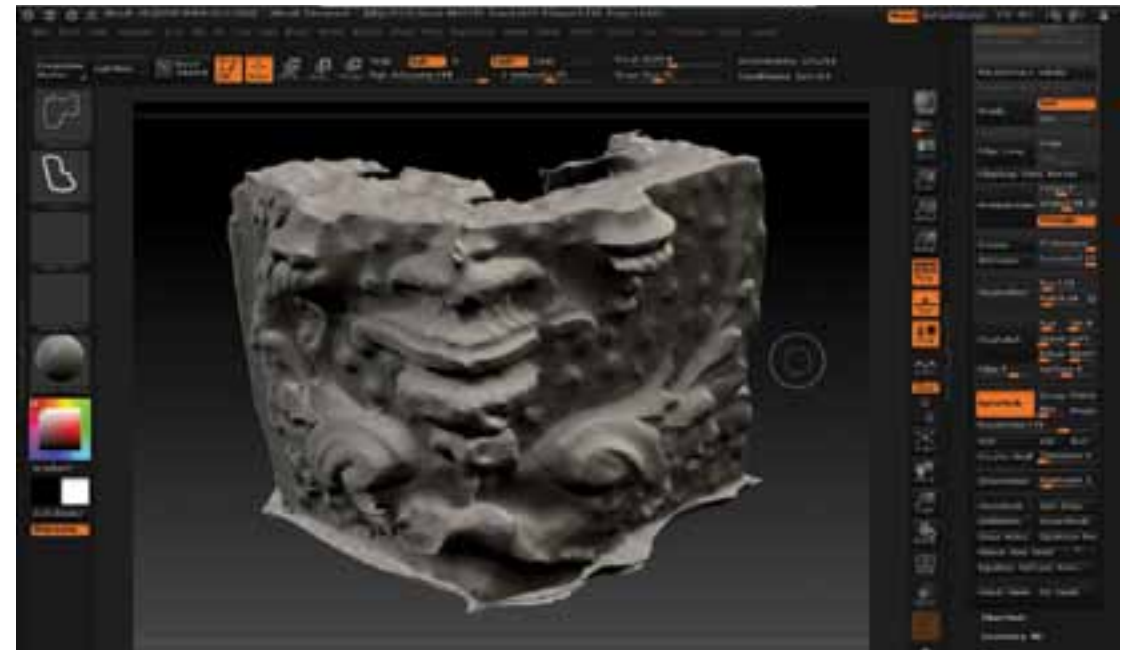

Digital Capture & Reproduction

Product output and quality contributions begin right from the start. During site survey, blocks marked for replacement are photographically documented. From these photos, using specific software packages, 3D models of the blocks marked for replacement are electronically generated and can be manipulated to produce shop drawings for architect/owner review and approval.

Once approved, these 3D electronic models are used to generate laser cut profiles to fabricate models and molds for replacement blocks. Time is saved during site survey, shop drawing production, and model/mold fabrication. Our expert staff moves less product, thereby reducing physical requirements of their workday and frees them to focus on a greater number of project specific requests. The accuracy of digital capture and laser cutting increases quality, predictability and consistency of replacement block fabrication.



R&D Color Development

R&D of glaze and through-body clay color formulation proceeds concurrent with site survey work and the design/drafting department. Physical control samples are studied, glaze and clay recipes are formulated and tested for a match to the control sample, then submitted to the architect/owner for review and approval. For single color samples, the acceptable color and range are scanned into a Spectrophotometer to set the acceptable color range for that project. Use of this high-tech color sensing device ensures that the product shipped to the site is consistent with the approved color sample. On some larger projects, a third-party inspection group is selected by the architect/owner to visit Boston Valley Terra Cotta at regular intervals to review terra cotta replacement blocks prior to being packaged and shipped to the project site.



BELOW: A single color glazed unit is checked with a Spectrophotometer.



Our bar coded tracking system tool provides a unified method for monitoring project status, from material supply award through final shipment and project close out.

Custom Designed Tracking System

Throughout each stage of the manufacturing process, Boston Valley incorporates our custom designed tracking system to assign unique identifiers for each sample received from the building to associate it with replacement units shown on the shop, setting, section and detail drawings generated by our skilled design and drafting departments. Our bar-coded tracking system tool provides production schedule accountability, product delivery updates for contractors to coordinate equipment and labor need at the project site, and a unified method for monitoring project status from material supply award through final shipment and project close out.

On a larger scale, our manufacturing facility is monitored from the outside for quality control and assurance through professional affiliations with groups like University at Buffalo Instrumentation Center and The Center for Industrial Effectiveness (TCIE) a part of the School of Engineering and Applied Sciences mentioned earlier in this section. From individual blocks to our expansive manufacturing facility in Orchard Park, New York, Boston Valley Terra Cotta employs the latest technology, quality control services and innovative tools to ensure product quality, consistency and production schedule accuracy. We understand that our clients have demanding schedules and utilize those tools available to us to make their work at the project site easier.



COLOR & FINISH OPTIONS

Custom Clay Body Color

Boston Valley Terra Cotta's architectural terra cotta products can be manufactured in custom through-body colors to match a historic clay body. The through-body color means that the color of the final product is achieved through a combination of clays, minerals and/or stains which are mixed with water and fired to a high temperature, forming permanent bonds.

For new masonry construction, BVTC will work with the architect to create a custom through-body color if specified for the project. The architect can use other materials including paint colors, pantone colors and additional façade materials such as stone as a reference when requesting a custom through-body color.

Color Range

As a natural product made of material mined from the earth, terra cotta exhibits a subtle color range upon firing in both the through-body and glaze finish options. This range, and the plasticity of clay that allows for variation in profile, make terra cotta a truly beautiful building material. Boston Valley works with our clients to clarify the inherent color range and understand what is required for their project.

Glaze Finishes

Having had 30 years of experience replicating historic glazes, Boston Valley Terra Cotta has a large successful history and glaze finish library to draw upon for your restoration or new construction project. Glaze finishes are available in matte, satin and gloss to replicate the level of sheen in the glaze finish on the historic block, or to produce the level of sheen required for your new construction project. BVTC works with clients to produce a glaze that replicates the historic sample or color swatch as close as possible using materials available in today's market. Production begins once drawings and glaze approval are received.



Texture

Various texture options are available for our product line. Beyond the natural ceramic finish achieved through the firing process, Boston Valley can provide barked, wire-struck, raked, grooved, stippled, and dimpled finishes for our products.

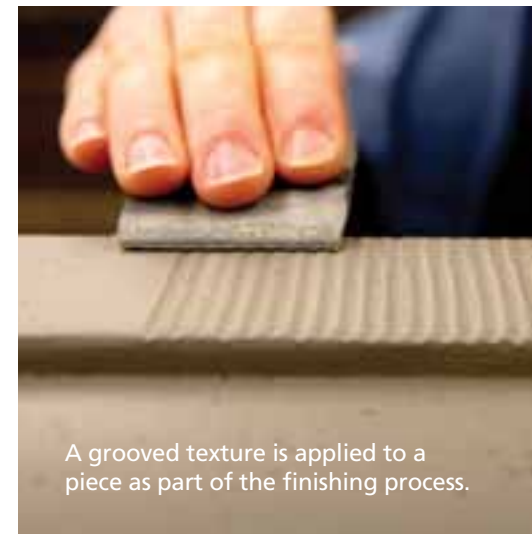

A grooved texture is applied to a piece as part of the finishing process.





Extruded units packed and ready to be shipped to the job site.

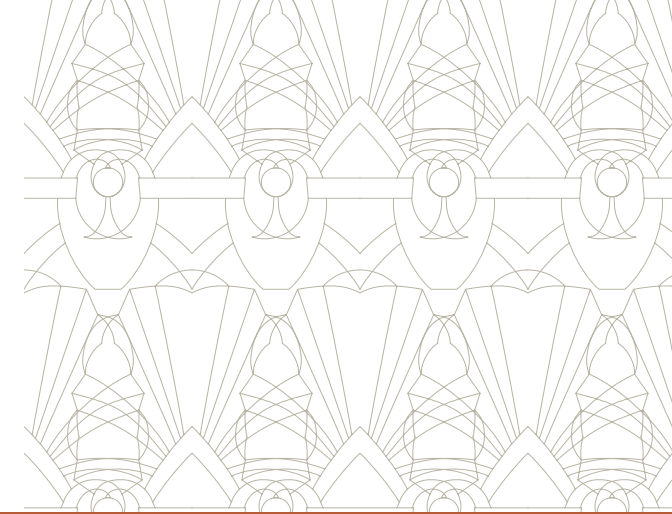

EXTRUSION DIE CATALOG

Extrusion Die Catalog | 64

ASHLARS & QUOINS

BANDINGS

COLUMNS

COPINGS

CORNICE

HEADERS & JAMBS

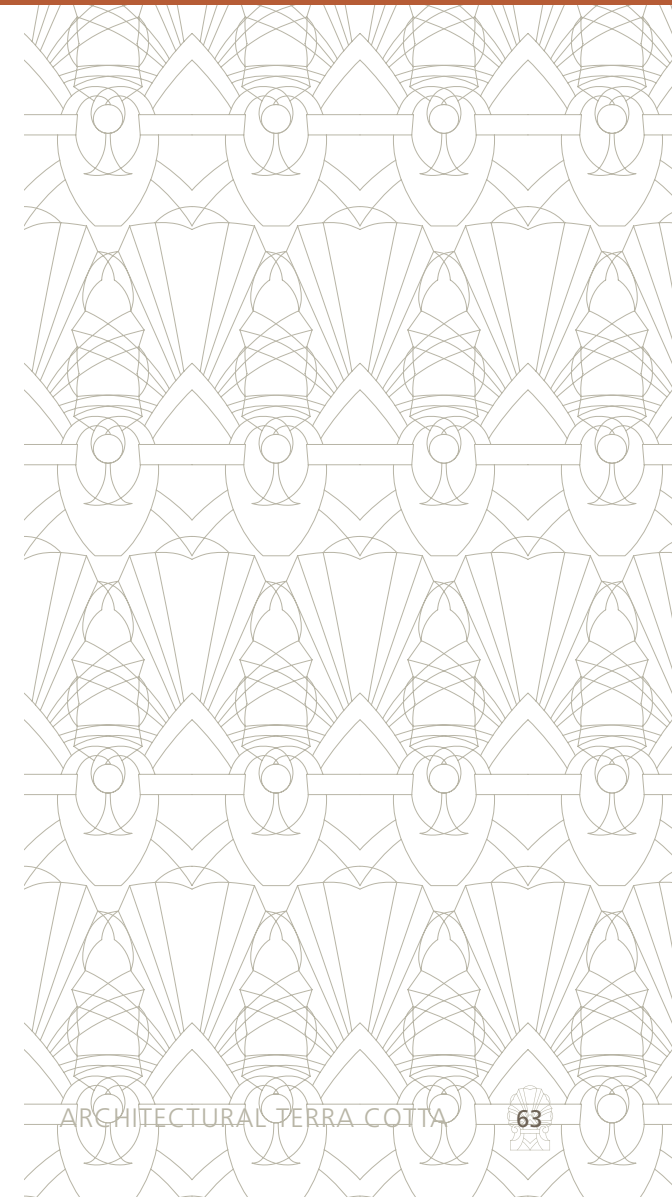



Ashlars & Quoins

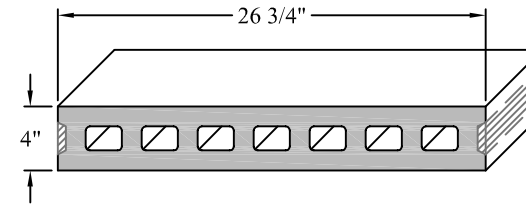

01-0114-A

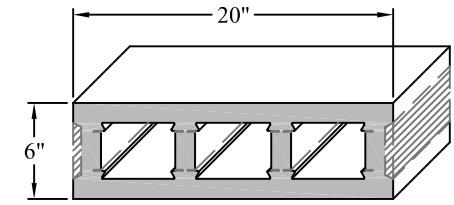

01-0102-A

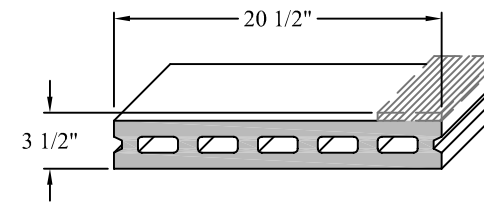

01-0149-A

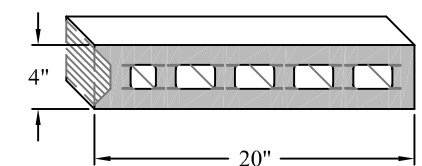

01-0134-A

EXTRUSION DIE CATALOG

With more than 30 years of completed projects in Boston Valley Terra Cotta's portfolio we have amassed countless steel extrusion dies to produce terra cotta blocks with classic profiles detailed for historic buildings – in some cases 100 years ago. These specialty profiles can be incorporated into masonry construction to distinguish your design from the rest. The design opportunities for profile and glaze color provide architects and owners with another pallet of tools when considering their next building project or addition to a historic structure.

The extrusion dies shown on the following pages in many cases have been used in projects shown in the New Construction section of the brochure and called out in the associated details. Take some time to review the dies shown, the New Construction projects and details and imagine the possibilities.

Bandings

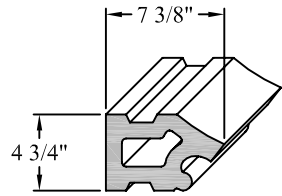

02-0206-B

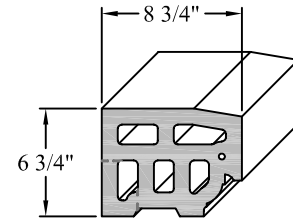

02-0217-B

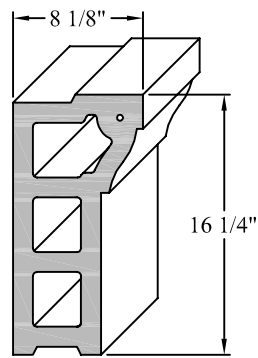

02-0209-B

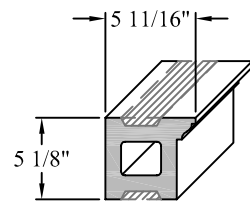

02-0219-B

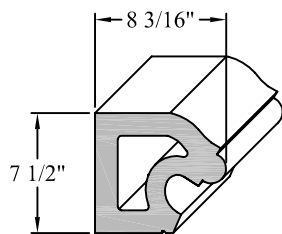

02-0220-B

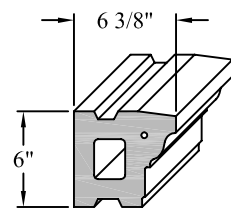

02-0227-B



Bandings

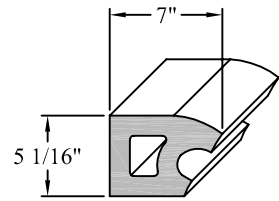

02-0221-B

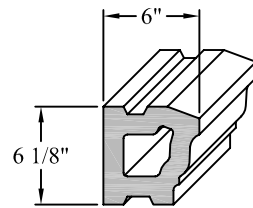

02-0229-B

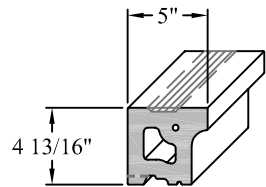

02-0222-B

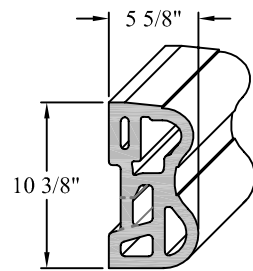

02-0230-B

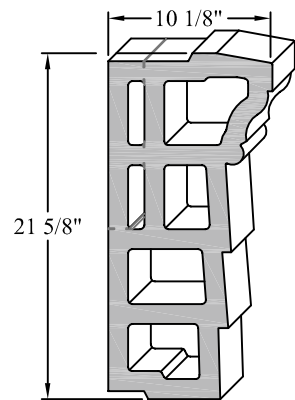

02-0231-B

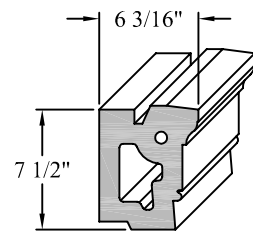

02-0236-B



Bandings

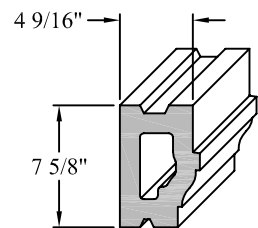

02-0232-B

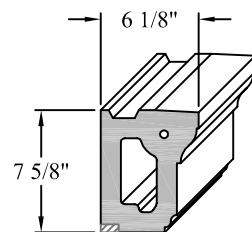

02-0237-B

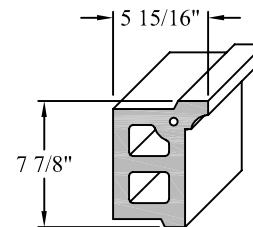

02-0243-B

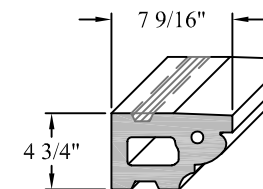

02-0254-B

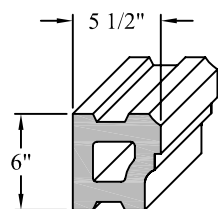

02-0235-B

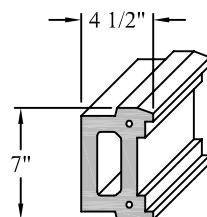

02-0239-B

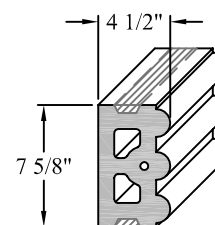

02-0251-B

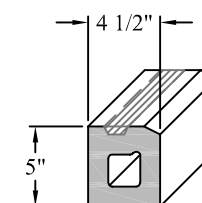

02-0255-B

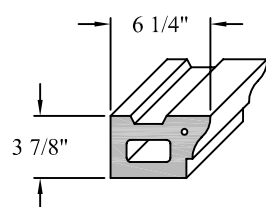

02-0241-B

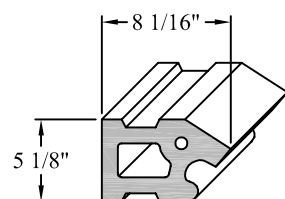

02-0253-B

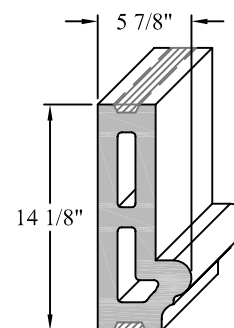

02-0256-B

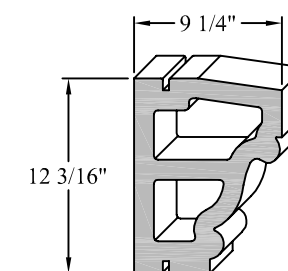

02-0267-B

Bandings



Bandings

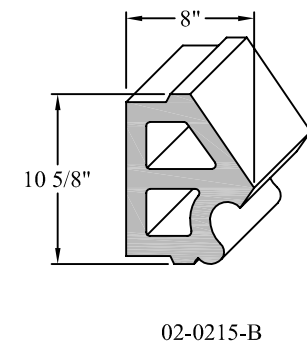
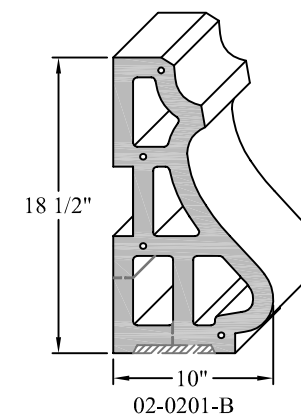
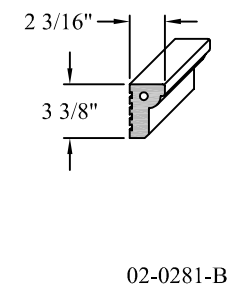
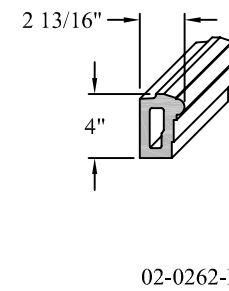
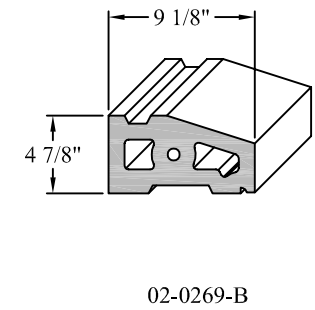
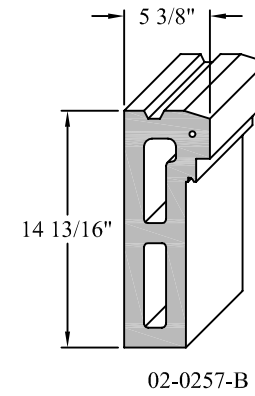

Columns

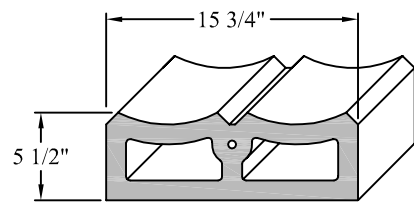

03-0309-CS

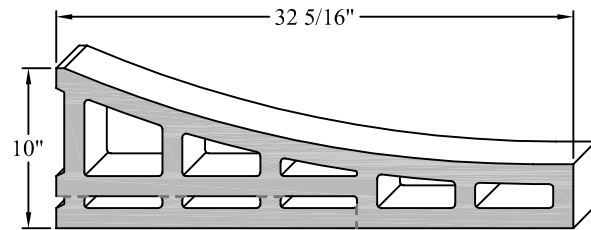

03-0318-CS

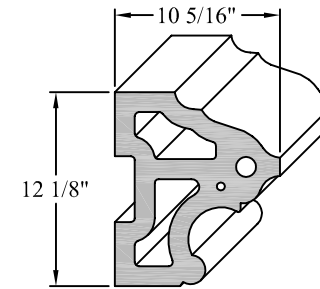

06-0603-HJ

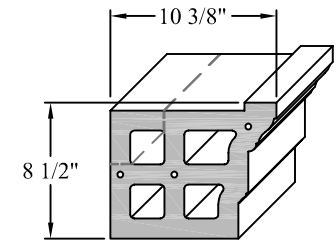

06-0610-HJ

Copings

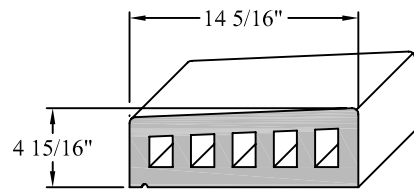

04-0401-CP

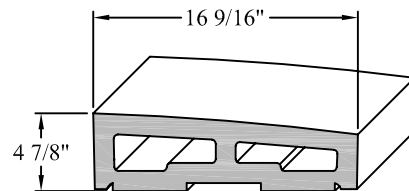

04-0408-CP

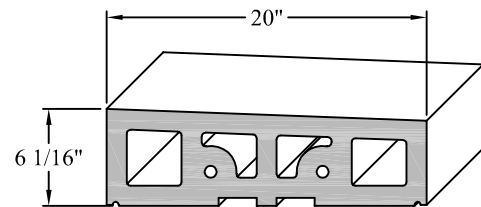

04-0425-CP

Cornice

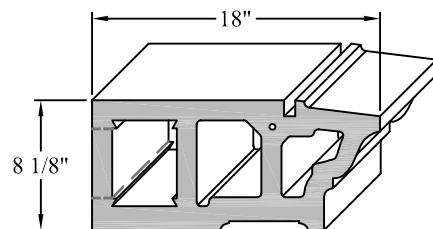

05-0501-CN

Headers & Jamb





Boston Valley utilizes recycled materials in its manufacturing process as part of its commitment to sustainability.

PERFORMANCE & SUSTAINABILITY

Product Testing | 78

PERFORMANCE TEST & DESCRIPTION

Sustainability & LEED Information | 78

MATERIAL & RESOURCE

Technical Data Sheet | 79

Performance Test & Description

ASTM C99

Standard Test Method for Modulus of Rupture of Dimensional Stone

ASTM C126

Standard Specification for Ceramic Glazed Structural Clay Facing Tile, Facing Brick and Solid Masonry Units

ASTM C880

Standard Test Method for Flexural Strength of Dimensional Stone

ASTM C1167-03 & ASTM C67

Standard Specification for Clay Roof Tiles (with modifications as required to ASTM C 67 - Standard Test Method for Sampling and Testing Brick and Structural Clay Tiles)

SUSTAINABILITY & LEED INFORMATION

Material & Resource

MRCREDIT 2.1, 2.2

**CONSTRUCTION WASTE MANAGEMENT
DIVERT 50% & 75% FROM LANDFILL**

INTENT: Divert construction, demolition and land clearing debris from landfill disposal. Redirect recyclable recovered resources back to the manufacturing process. Redirect reusable materials to appropriate sites.

REQUIREMENT: Recycle and/or salvage at least 50% or 75% of construction and demolition debris (by weight or volume). BVTC will accept recovered terra cotta scrap or pieces from the project site to reuse in the manufacturing process.

MRCREDIT 4.1, 4.2

RECYCLED CONTENT

10% & 20% POST CONSUMER & 1/2 PRE CONSUMER

INTENT: Increase demand for building products that incorporate recycled content materials, therefore reducing impacts resulting from extraction and processing of new virgin materials.

REQUIREMENT: Use materials with recycled content such that the sum of post-consumer recycled content plus one-half of the post-industrial content constitutes at least 10% or 20% of the total value of the materials in the project.

MRCREDIT 5.1, 5.2-

**REGIONAL MATERIALS
10% & 20% EXTRACTED, PROCESSED
& MANUFACTURED REGIONALLY**

INTENT: Increase demand for building materials and products that are extracted and manufactured within the region, thereby supporting the regional economy and reducing the environmental impacts resulting from transportation.

REQUIREMENT: Use building products that have been extracted, harvested or recovered, as well as manufactured, within 500 miles of the project site for minimum of 10% or 20% of the total materials value (based on cost). If only a fraction of the product is extracted, harvested or recovered and manufactured locally, then only that percentage (by weight) shall contribute to the regional value. Approximately 42% of the raw material BVTC uses in the manufacture of its terra cotta product is harvested within 500 miles of our manufacturing facility in Orchard Park, New York.

This information provides a credit summary of Boston Valley Terra Cotta's product relevant to the USGBC's LEED® Rating System. Please contact BVTC for LEED® credit information as it relates to specific needs for your project.

Technical Data Sheet for Terra Cotta

Material Property	Test Value
Compressive Strength	ASTM C67 & ASTM C126 6000 psi
Absorption (5 hour boil)	ASTM C67 11.5%
Absorption (24 hour soak)	ASTM C67 7.5%
Saturation Coefficient	ASTM C67 0.69
Freeze/Thaw Cycles w/out Degredation	ASTM C67 300 Cycles Passed
Weight per Unit Area	ASTM C67 130-135 lbs/ft ³
Linear Coefficient of Thermal Expansion	3.5 x 10 ⁻⁴ percent (0.035%)
Hardness Resistance Mohs Scale	Various Standard Colors 7-9
Glaze Absorption	ASTM C67 0.15%
Craze Resistance	ASTM C126
Efflorescence	ASTM C67 No Efflorescence
Chemical Resistance	ASTM C126-99 No Change in Color or Texture
Dimensional Tolerances	Value
Sized Length & Width	+/- 1/16"
Non-Sized Length & Width	+/- 1/8" Per Linear Foot
Warpage – Restoration	No more variance from true plane than original
Warpage – Extruded Ceramic Veneer	No more variance from true plane than .005" per inch of length



Projects Featured in this Book

90 WEST STREET
PAGES 12, 24–25

200 ELEVENTH AVENUE
PAGES 34–35, 75

520 WEST CHELSEA
PAGES 26, 32–33, 69

DETROIT PUBLIC LIBRARY
PAGES 22–23

FLUSHING HIGH SCHOOL
PAGES 14–15

FREDERIC H. PEASE AUDITORIUM,
EASTERN MICHIGAN UNIVERSITY
PAGES 18–19, 72

HEARST TOWER PLAZA
PAGES 36–37, 69

OLD PLANK TRAIL COMMUNITY BANK
PAGES 30–31

STOECKEL HALL, YALE UNIVERSITY
PAGES 4, 20–21

UTAH STATE CAPITOL
PAGES 16–17

WEST LAFAYETTE PUBLIC LIBRARY
PAGES 38–39



Printed April 2012

Printed on 110# Mohawk Loop Feltmark Natural Cover and 100# Mohawk Loop Ivory Text.
This book is produced using paper with 50% Post Consumer Waste and is 100% recyclable.

MOHAWK windpower 