

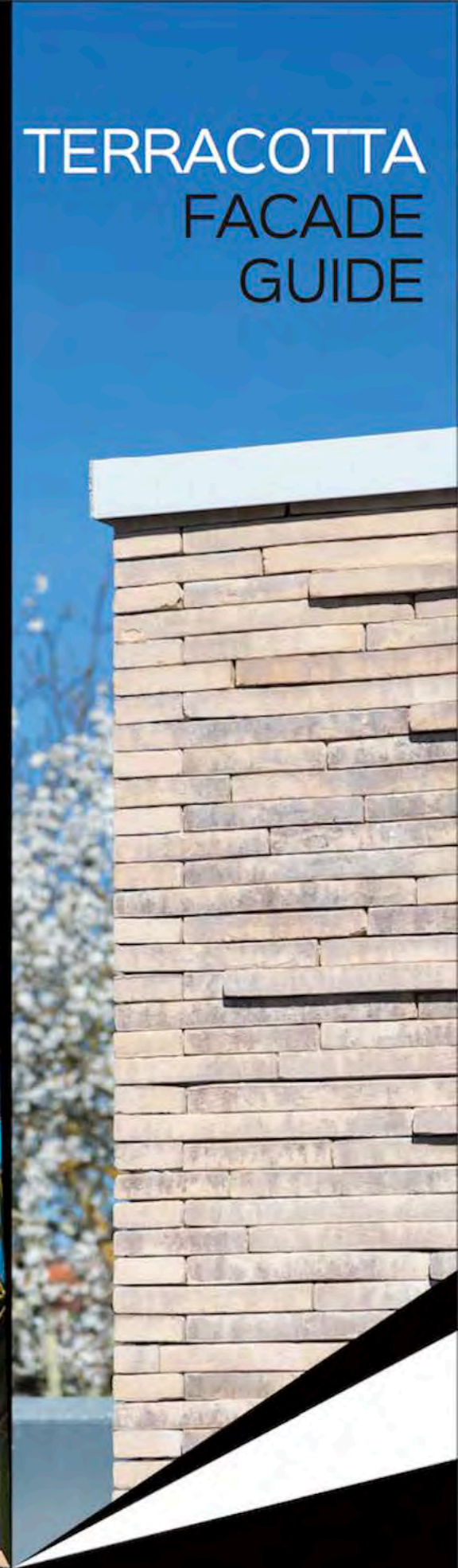

# TERRACOTTA FACADE GUIDE



**TERREAL**

Building beauty

# Revealing the beauty of terracotta in every building

TERREAL is an innovative and responsible manufacturer with its roots in terracotta building materials. The Group has just under 2450 employees across 12 countries.

TERREAL provides complete building envelope solutions across four major product areas: Roofing, Structure, Façade and Decoration.

Our mission? To work every day to develop local areas and promote sustainable, beautiful and functional housing that respects both people and the environment. Working with clay and letting it inspire us – to change the everyday into something unique.



**412 M€**  
TURNOVER

including the acquisition of  
GSE Integration



**2230**  
EMPLOYEES

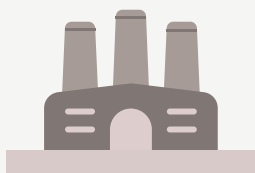

**21**

INDUSTRIAL SITES

France, Italy, Spain, Portugal, USA



**6**

SALES OFFICES

Bahrain, China, Singapore, Thailand,  
UK & USA

# Table of contents

## PRODUCTS OVERVIEW

- Terreal, 4 expertises .....p4
- A global company .....p5
- Recommendations .....p6

## RAINSCREEN CLADDING RANGE

- Piterak® Slim .....p8
- Piterak® XS .....p42

## SUNSCREEN RANGE

- Autan®, Harmattan®, Zonda® XL & Shamal® XL range .....p62

## FACING RANGE

- Classic brick .....p78
- Glazed colours .....p84
- Hand-moulded brick .....p86



# Terreal, 4 expertises

We can respond fully to the building envelope needs of homebuilders. Our range of products and services is divided into 4 major product areas :



## ROOFING

[www.terrealcouverture.com](http://www.terrealcouverture.com)



## STRUCTURE

[www.terrealstructure.com](http://www.terrealstructure.com)



## SOLAR

[www.terrealcouverture.com](http://www.terrealcouverture.com)

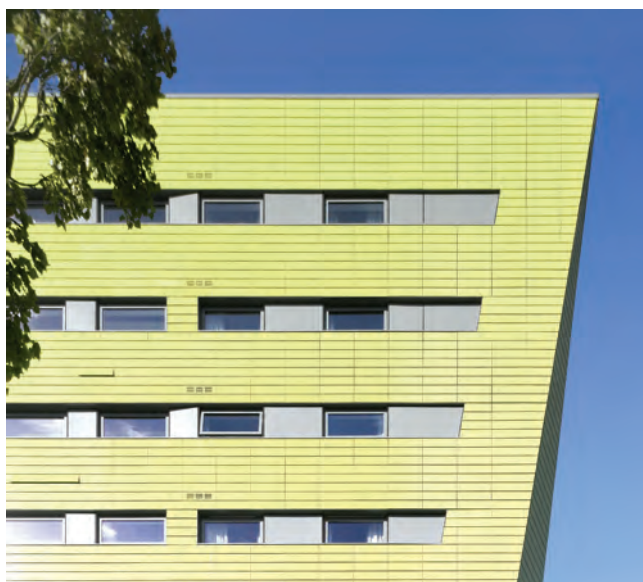

## FAÇADE-DECORATION

[www.terrealfacade.com](http://www.terrealfacade.com)

# A global company

From China to the United States, TERREAL operates worldwide to seek out the best production sites and promote its products. A key player in construction materials, we have locations in every corner of the globe.

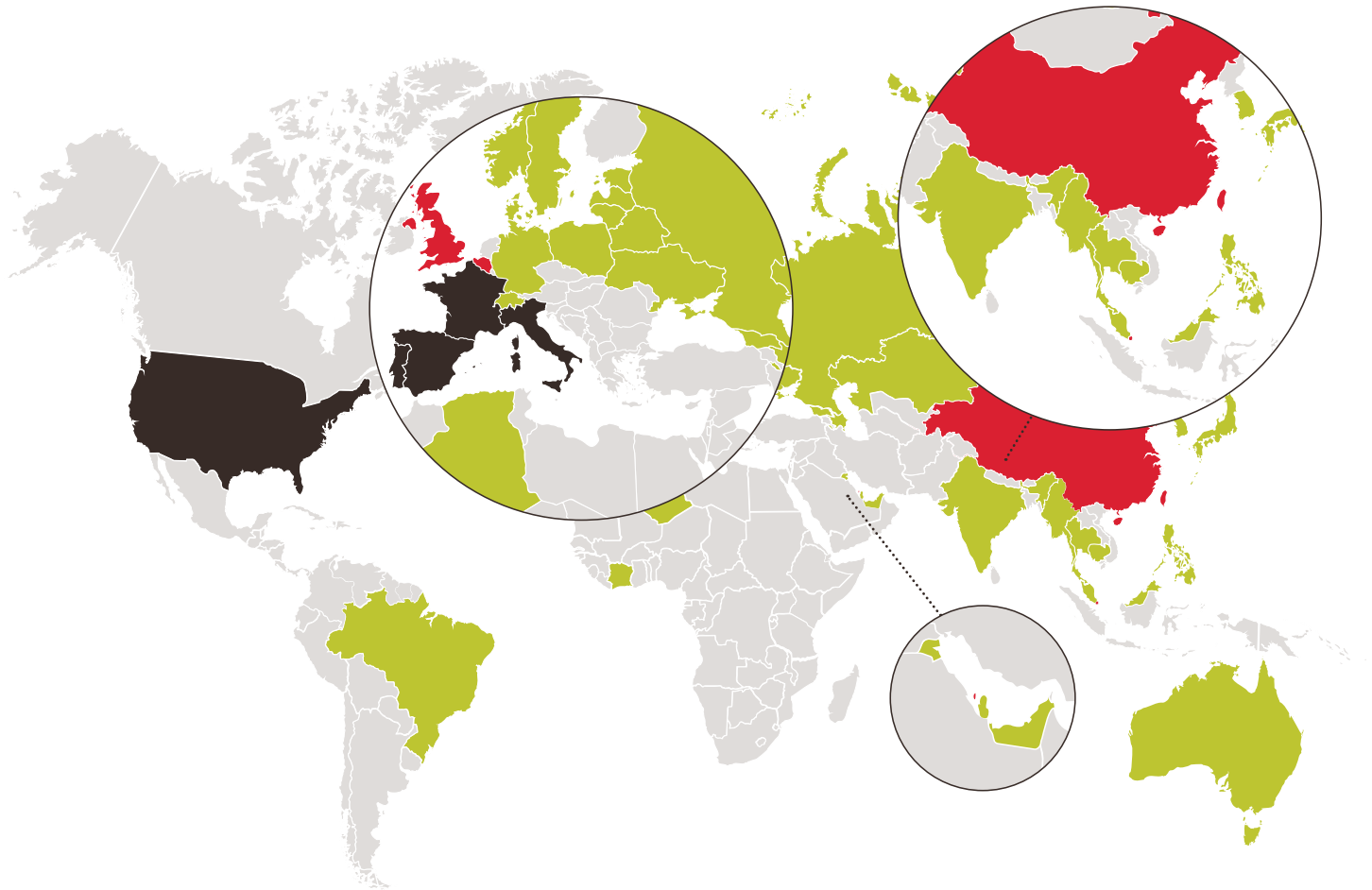

- Industrial presence
- Sales offices
- Partner-Distributors

## RECOMMENDATIONS

---

# Terracotta façade cleaning process

Generally, terracotta is self-cleaning but it may need cleaning at regular intervals depending on the local environmental conditions where the terracotta tiles are situated.

### GENERAL RECOMMENDATIONS :

Before to start any cleaning process, it is highly recommended to perform a first test on a small facade non-visible or a less visible surface.

#### In case of using high pressure water jet:

It can be used with care in front of the joints in order to avoid any damage to the insulation panels of rainscreen facades or mortar layer of a brick wall.

#### In case of using detergent :

- ALWAYS follow the user instructions and recommendations given by the manufacturers of the detergents used.
- ALWAYS use personal protection equipment such as masks, glasses, gloves for any cleaning operation.

**These recommendations are just indicative and we recommend you to approach a Specialist Company such as Guard industries, Evonik, Sika or others...**

### POSSIBLE SOURCES OF DISORDER

#### Environment impact

- Moisture can bring minerals to the terracotta surface and allow efflorescence to develop.
- Pollution can create an accumulation of dust and dirt on the surface of facades.

#### Live work site

- Storage and cutting can create dust and dirt on the products.
- Grease residues maybe present on fixing accessories. During the installation and handling of all the components on the system, it is possible to stain terracotta tiles.
- It is essential to store all products in a safe, secure place on a flat, level and stable surface to avoid potential staining on site.

#### Irregularities during installation of details

- The inadequate flashing detailing for drainage of rain water drainage can result in the development of unsightly staining from moss growth (greenish, blackish...). Recommended Advice: Metal flashing must be correctly installed to avoid such staining.
- Failure to respect the distance at the bottom of the façade will risk moisture development. As a consequence, moss growth and unsightly staining can appear so care with this detail is essential.

### HOW TO CLEAN DUST AND DIRT?

- Cleaning with water (repeating more than once maybe necessary).

- Allow to dry after each application.
- If stains are persistent, try cleaning with a clean sponge and clean water before allowing to dry.
- The use of a high-pressure water jet is possible but with special care is essential in the vicinity of the tile joints in to avoid damage the insulation panels.

### HOW TO CLEAN GREASE STAINS?

- Clean with water and neutral PH soap (several cleaning operations may be necessary).
- Rinse with clean water and allow to dry.
- If grease stains are persistent, use a powerful diluted detergent and follow detergent manufacturers recommendations.
- Rinse with clean water and allow to dry.
- Repeat this process if necessary.

#### Advised detergents add

- CERMINET (Desvres)
- ALGICIMENT (Algimouss)
- SIKA DECAP (Sika)

#### Information about Efflorescence

- Efflorescence is a natural phenomenon which results in white chalky deposits on the surface of a natural material.
- Efflorescence can be from different causes, the most frequent is due to the calcite present in the raw material. This calcite can appear on the surface of the terracotta at any given time and more often due to an area of excessive moisture.
- It disappears naturally during the lifetime cycle. The quality of product is not affected.
- In case of brick slips, mortar joint can generate efflorescence onto surface. It is recommended to clean facades after mortar laying, respecting product specifications.

### HOW TO CLEAN CALCITE EFFLORESCENCE AND WHITISH COATING?

- Protect the metallic flashing (around the windows, angle) near to the cleaning area.
- Apply water onto the affected area.
- Clean product from the top to the bottom of the product with a sponge on the following blend: 1 part of hydrochloric acid (diluted at 30%-35% in volume) into 9 parts of clear water. (If it generates white foam when applied on terracotta, the efflorescence is confirmed as a calcite one.)
- Rinse thoroughly with water (low-pressure water jet). Do not wet the product non-treated with an acid.
- Allow to dry.
- Repeat this process if necessary.

**HOW TO CLEAN MOSS? (greenish, blackish, ...)**

- Clean with water (more than once may be necessary, a low pressure jet can be used)
- Let dry.
- Repeat this process if necessary.

**Information about Moss**

- The appearance of moss is due to poor treatment of singular points facilitating rain water onto the facade surface. The blend dust and water and constant moisture on to water paths on the façade surface allows the appearance of moss.
- To avoid the reappearance of mosses after cleaning, it is recommended as far as possible to modify the failing singular point.

**HOW TO CLEAN GRAFFITI?**

The cleaning method must to be chosen according to type of the graffiti product used, the type of finishes and the surfaces. Glazed finishes will be easier to clean than textured finishes or natural surfaces.

It is recommending to address your requirement directly to a professional cleaning service which can advise you the best method on a case by case basis (scrub, rubbing, cover method, etc.)

**Anti-graffiti** products may be considered as a preventive solution, especially at ground level. However, these kind of treatments may change the original appearance of the surface of the terracotta. It is strongly advised that if it is decided to pursue this type of solution, to test the product/s first on one of the pieces in a discreet location of the façade or if at time of installation on a spare tile to decide of a products effectiveness.

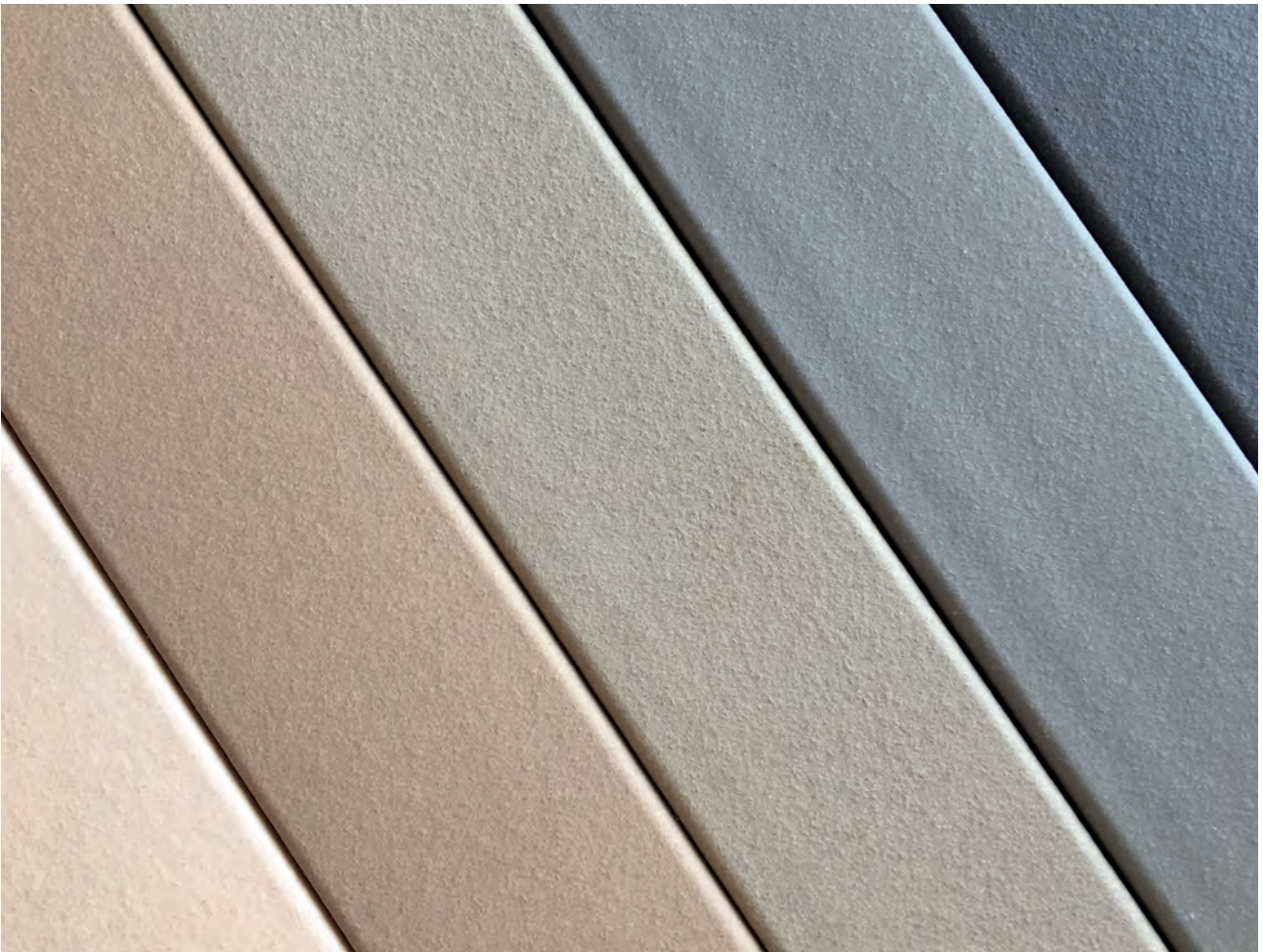



# Rainscreen cladding range

Modern, authentic and environmentally friendly, the Terreal wall cladding product range continually invigorates its application techniques and aesthetics. It offers highly effective solutions that meet the latest thermal, seismic and environmental regulations. It is resistant to impact, wind and frost, and is certified by technical assessments issued by the CSTB organization and other engineering organizations around the World.

Durable, maintenance free, and economical, our products are made from clay, a natural raw material, and benefit from the expertise of a major corporation to constantly progress.

# Piterak® Slim

A rainscreen cladding sized to seduce



Piterak Slim is a 30mm thick, double-skin terracotta rainscreen cladding system with overlapping horizontal reveals. The system contains a large module terracotta panel available in a variety of standard sizes and a multitude of made-to-order sizes with a maximum height of 60 cm and maximum length of 180 cm. The system provides high wind resistance and the highest (Q4) impact resistance rating under French CSTB standards (an ICC Construction Product Evaluation Expert Alliance member).

## STRENGTHS

- Long length : up to 180 cm
- Heights from 15 to 60 cm
- Many customization possibilities : colour, finish, shape
- Choice of installation : horizontal, vertical
- High impact performance
- Maintenance free and durability
- Fire resistant

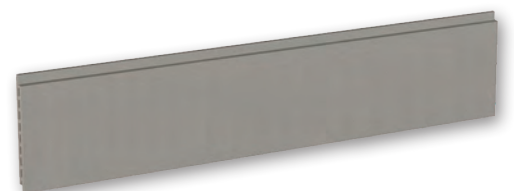

VERDE STUDENT RESIDENCE, NEWCASTLE, UK

Architect : Simpson Haugh and Partners

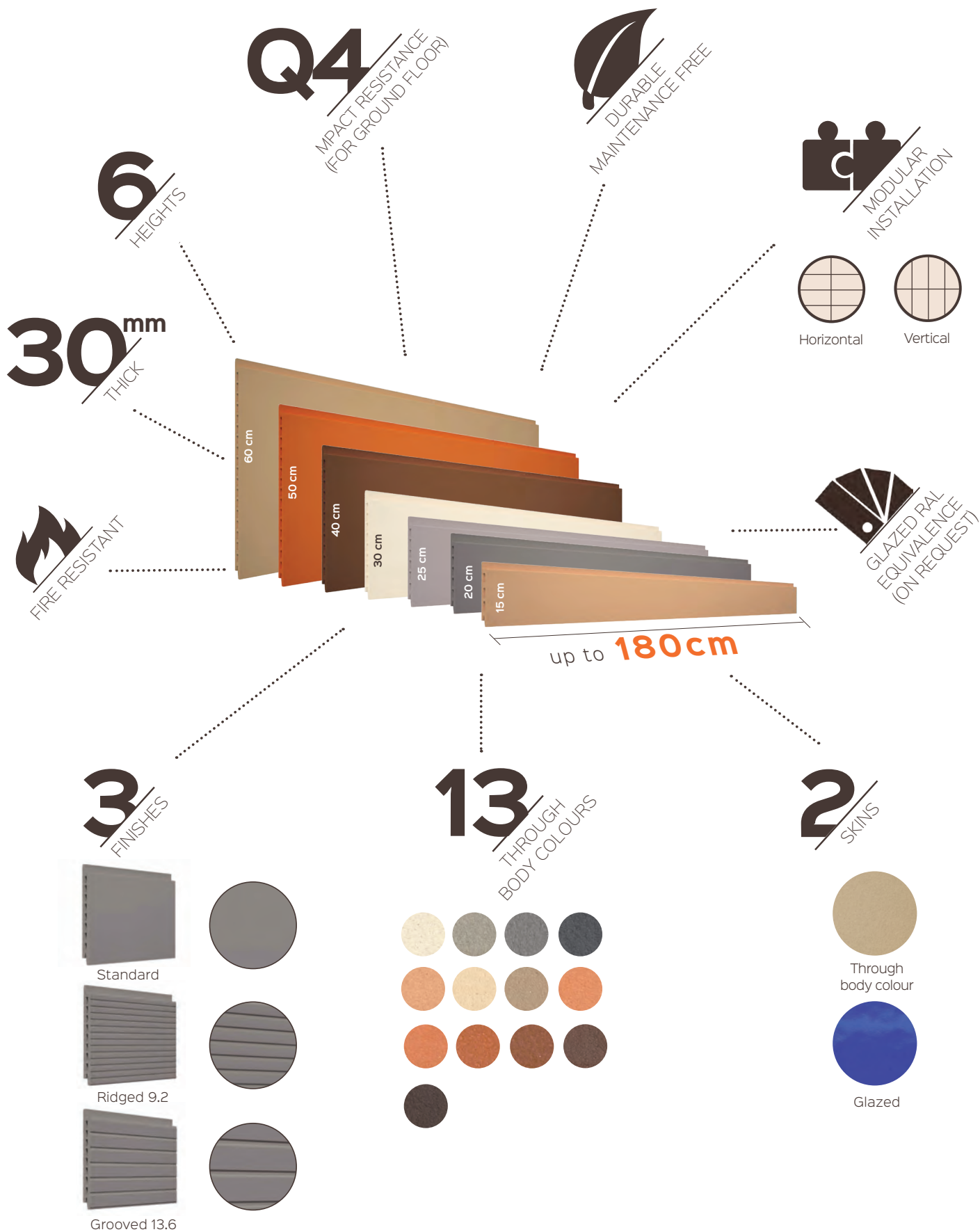

# Standard range

## STANDARD DIMENSIONS

REF. CATALOGUE	MODULE HEIGHT	MODULE LENGTH	THICKNESS	WEIGHT / M <sup>2</sup>
PS15C0	150mm	310 to 1810 mm	30 mm	~48,5 kg / m <sup>2</sup>
PS20C0	200 mm			
PS25C0	250 mm			
PS30C0	300 mm			
PS40C0	400 mm			
PS50C0	500 mm			
PS60C0	600 mm			

## FINISHES

### Standard

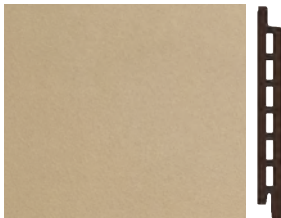

### Ridged 9.2



Ridge dimension :  
Height 9 mm  
Depth 2 mm  
Ridges each 25 mm

### Grooved 13.6



Grooves dimensions:  
Height 13 mm  
Depth 6 mm  
Grooves each 50 mm

## THROUGH BODY COLOURS

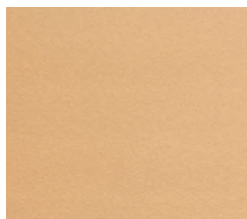

06. Sand

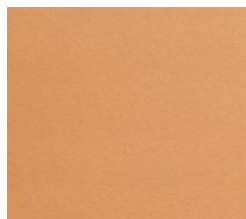

04. Salmon

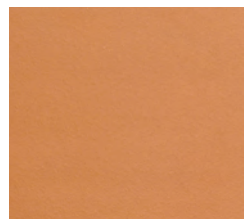

02. Red-orange

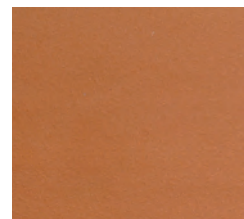

01. Red

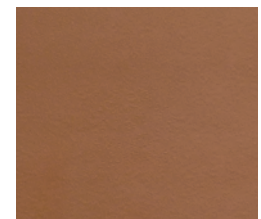

07 Sienna

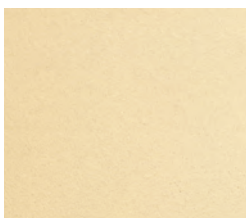

03. Champagne



11. Sahara beige

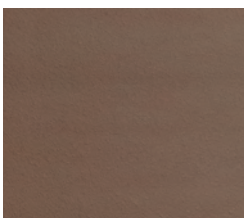

09. Coffee

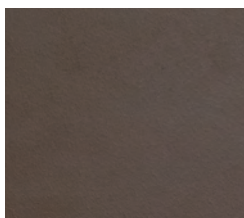

16. Ebony



12. Light grey

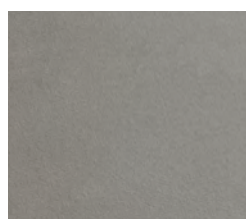

13. Storm grey

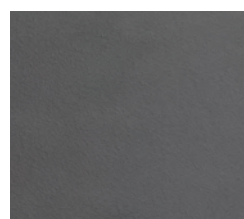

15. Slate grey



30. Arctic white  
(Engobed colour)

# GLAZED RANGE COLOURS



Yellow



Lichen



Orange



Red



Mars Red



Petrol blue



Cobalt blue



Egyptian violet



Calamine pink



Shadow earth



Green



Verdigris

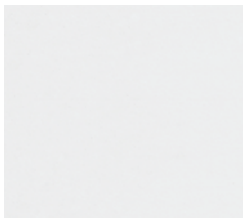

Matt white



Glossy white



Matt light grey



Glossy light grey

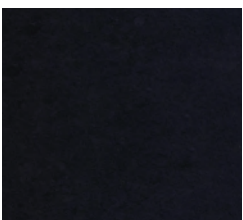

Matt black



Glossy black

## Metallic colours

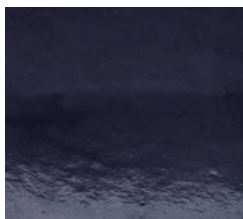

Marine black



Steel

### Custom glazed colour

TERREAL can develop on request RAL equivalent glazed colours in matt or glossy appearance.

# System characteristics

## SYSTEM DESCRIPTION

Cladding process based on 30 mm thick double-wall terracotta products (~48,5 kg / m<sup>2</sup>) with a horizontal overlap, held using special clips, to a vertical steel framework secured to the main structure, with insulation fitted behind the framework.



## CHARACTERISTICS

- Modulus of rupture > 15 MPa
- Water absorption 6 to 9%
- Frost resistance
- Fire classification A1: firing mass considered to be zero

### Fixing system

The fastening clips are made of stainless steel 1.4301 according to standard EN 10088.

The vertical support profiles are made of aluminum EN AW 6060 according to EN 755-2.

### Impact resistance:

Highest (Q4) impact resistance rating under French CSTB for standard finishes. Without CSTB test, ridged and grooved finishes are rated Q3.

INSTALLATION	HEIGHT MODULE	MAXIMAL LENGTH	CLASSIFICATION FOLLOWING FRENCH NORM 08-301/302	STEEL BALL 0,5 KG	STEEL BALL 1 KG	SOFT BALL 3 KG		SOFT BALL 50 KG	
				DO,5	D1	M3		M50	
				1 joule	3 joules	3 joules	20 joules	100 joules	130 joules
Standard	20 to 60 cm	≤ 180 cm	Q4	✓	✓	✓	✓	✓	✓
Reinforced (add 1 vertical profile + clip at mid-span)	15 cm	≥ 120 up to 180 cm	Q4	✓	✓	✓	✓	✓	✓
		< 120 cm	Q3	✓	✓	✓	✓	✓	✓
Standard	15 cm	≤ 150 cm	Q3	✓		✓	✓	✓	
		≤ 180 cm	Q2	✓		✓	✓		

## PROPERTIES

### Support type:

- Concrete wall
- Coated masonry

### Certifications:

#### Product under technical assessment :

French CSTB 2.2 /13-1584 V1 and BBA 06/4298



Piterak® Slim 15 cm is not included in the certifications



### Wind resistance :

		STANDARD INSTALLATION		REINFORCED INSTALLATION*
		Module length (mm)		
		1530	Up to 1810	Up to 1810
MODULE HEIGHT (MM)	150	1654 Pa	1654 Pa	-
	200	1936 Pa		
	250	2219 Pa	986 Pa	1947 Pa
	300	2359 Pa		
	400	1465 Pa		
	500	962 Pa	962 Pa	Not tested
600				

### Fire resistance:

Non-combustible product: fire resistance class as A1

\* Reinforced installation with 1 intermediate profile and 2 adding clips.



**BIM objects available**

[www.bimobject.com/fr/terrealfacade](http://www.bimobject.com/fr/terrealfacade)

# Horizontal fixing system properties

## FIXING ACCESSORIES

Terreal provides :

- Clips for standard installation
- Vertical profiles



PITP01  
Omega profile ridged  
Piterak®  
SAP 118027



PITP06  
Omega profile  
Piterak®  
SAP 140961



PITP03  
Angle profile ridged  
Piterak®  
SAP 118028

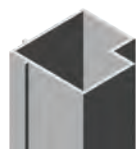

PITP04  
Angle profile Piterak®  
SAP 118020



PITP05  
Y profile Piterak®  
SAP 31298



PITP07  
T profile Piterak®  
SAP 152738



PSLA01  
Standard clip  
Piterak® Slim  
SAP 124522



PITA02  
Upper clip  
Piterak® Slim  
SAP 105531



PITA04  
Clip for movement joints  
Piterak® Slim  
SAP 131948



PITA05  
Under-sill clip  
Piterak® Slim  
SAP 132338

- Estimated quantity of fixing accessories for a standard implementation and without singular points.

Values given for information.

MODULE HEIGHT X LENGTH	PITERAK® SLIM	CLIP PSLA01	PROFILE
150 x 1000 mm	6,7 u / m <sup>2</sup>	13,4 u / m <sup>2</sup>	1 ml / m <sup>2</sup>
200 x 1200 mm	4,2 u / m <sup>2</sup>	8,4 u / m <sup>2</sup>	0,83 ml / m <sup>2</sup>
300 x 1300 mm	2,6 u / m <sup>2</sup>	5,2 u / m <sup>2</sup>	0,76 ml / m <sup>2</sup>
400 x 1500 mm	1,7 u / m <sup>2</sup>	3,4 u / m <sup>2</sup>	0,66 ml / m <sup>2</sup>
400 x 1800 mm	1,4 u / m <sup>2</sup>	2,8 u / m <sup>2</sup>	0,55 ml / m <sup>2</sup>
600 x 1800 mm	0,9 u / m <sup>2</sup>	1,8 u / m <sup>2</sup>	0,55 ml / m <sup>2</sup>

Here below the formulas to evaluate the indicative quantity per m<sup>2</sup> for an H x L frame in the running part without taking into account the singular points. H and L are the height and length of the module and are expressed in m.

ESTIMATED CALCULATION OF QUANTITIES HEIGHT X LENGTH	
Piterak® Slim / m <sup>2</sup> quantity	1 / (H x L)
Clip / m <sup>2</sup> quantity	2 / (H x L)
Profile / m <sup>2</sup> , quantity (ml)	1 / L
Profile / m <sup>2</sup> quantity (u)	1 / (3 x L)

- Other supplies necessary for the implementation are not offered by Terreal (insulation, fixing screws, dowels or lag bolts, brackets, profile bay trim, lower part starting grid, profile angle, ...). They are the responsibility of the installation company.



For the final order, a precise layout must be carried out by the installation company in order to take into account all the singular points of the site.



ZOOM ON ...  
Installation guide  
video

[www.youtube.com / user / terrealvideos](http://www.youtube.com/user/terrealvideos)



## PRIOR RECOMMENDATIONS

The implementation of vertical profiles must respect the rules of the technical assesment : French CSTB 2.2 /13-1584 V1 and BBA 06/4298.

The layout is carried out beforehand by the company installation, to determine the positioning of vertical profiles as well as the dimensions of Piterak® Slim.

To define the vertical layout correctly it is necessary to consider a vertical space between 2 products of 10 mm (this space can be increased to 20 mm maximum).



Make sure to respect a space of 20 mm minimum between the insulation and the back of the terracotta product to allow a good ventilation of the air gap.

**Check with local industry standards and local guidelines as requirements varies from Country to Country.**

## INSTALLATION

The vertical profiles are fixed to the walls by square brackets (or stirrups) fixed to the profiles by stainless steel drilling screws. So fixed this frame is called "bridle".

The profiles must be fixed so as to adjust the verticality and horizontality of the profiles between them.

The number and arrangement of the brackets (or stirrups) is determined by calculation, depending on the area of intended use, by the supplier of the brackets.

The implementation of Piterak® Slim is done from the bottom to the top, once the frame is aligned vertically and horizontally and that the insulation is put in place (when necessary).

Standard clip (PSLA01) in the bottom part are fixed in 1<sup>st</sup> while aligning with the horizontality. The clips are fixed to the vertical profiles with stainless screws.

The Piterak® Slim is placed on these clips, then the standard clips are laid at the ends of the upper part of the product. A space between the clip and the top of the terracotta should be spared.

To facilitate the installation / fixing of the clips, a tracing can be carried out on profiles at each module height (example for Piterak® Slim 30: height of 30 cm module = marking on profile every 30 cm).

Thus assembled, the horizontal joint between 2 products will be about 12 mm.

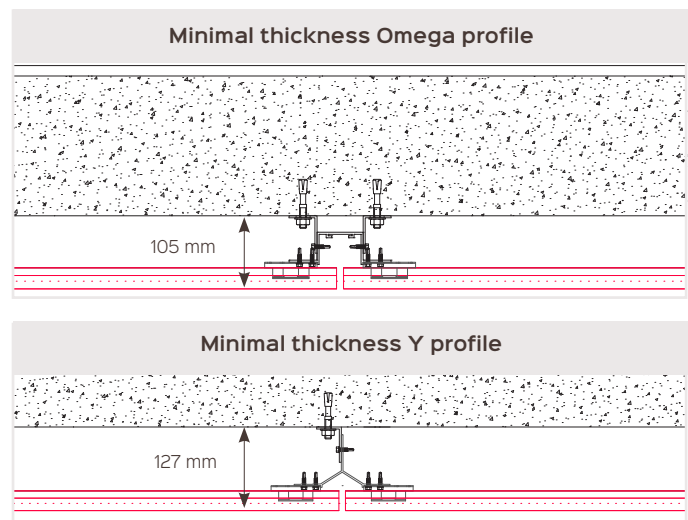
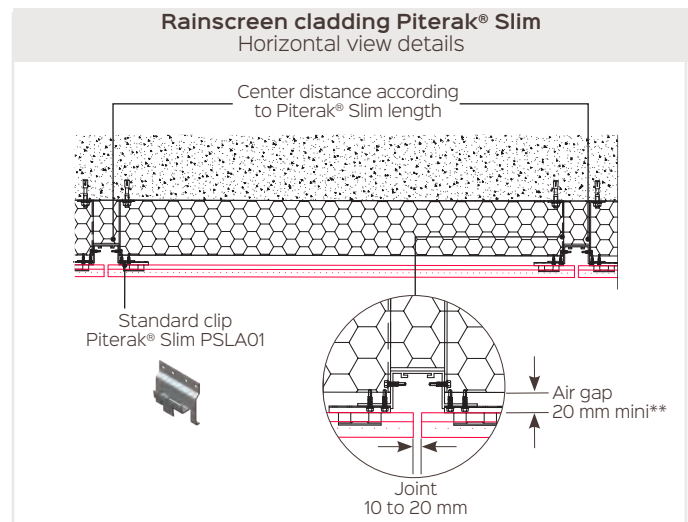
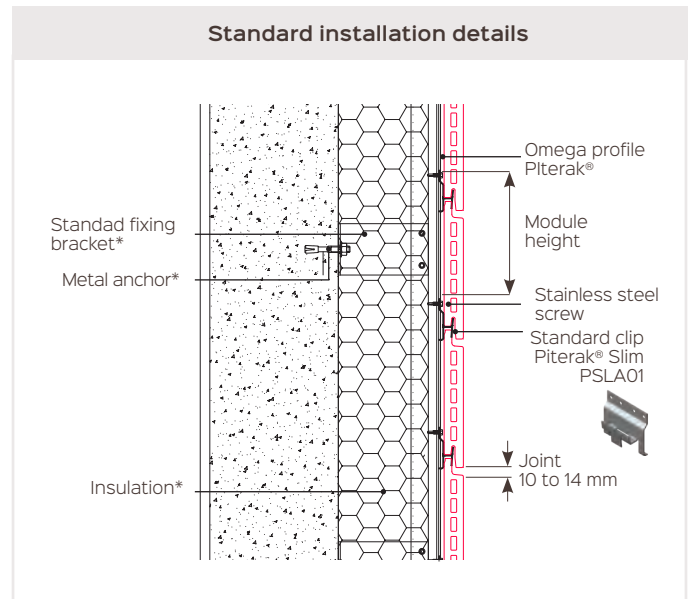

\*Not provided by Terreal

# Horizontal fitting guide



## SINGULAR POINTS

### Bottom details

In the lower part, it is necessary to respect a minimum height between the ground and the bottom of the starting Piterak® Slim element.

- Height is 50 mm on hard ground or 150 mm on soft ground for application on concrete wall or traditional coated masonry.

### Bottom detail

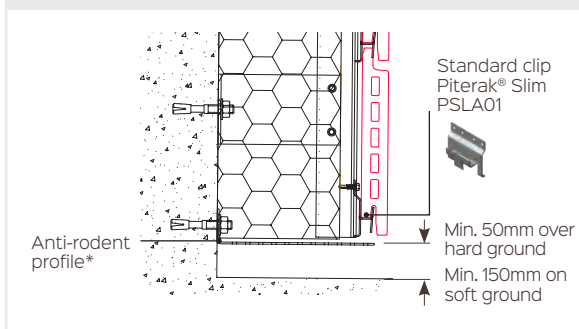

### Top details

A metal capping must be placed in the upper part or parapet to limit the penetration of rainwater.

- The metal capping must have a fall in front of the terracotta of 30 mm and must overhang the Piterak® Slim by at least 20 mm.
- Thus dimensioned, this flap prevents rainwater from flowing directly onto the Piterak® Slim and allows good ventilation of the air gap. A regular flow of water promotes the appearance of foam on the products: this degrades the aesthetics of the facade and results in a need of regular cleaning operation.

### Top detail

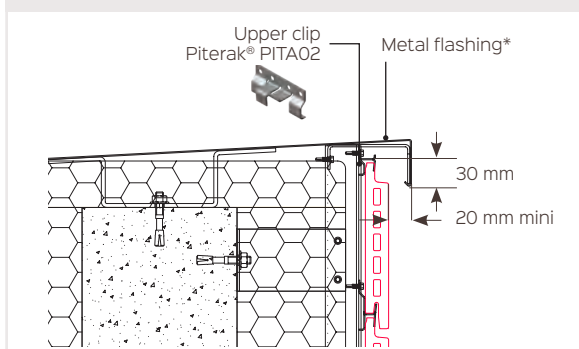

\*Not provided by Terreal

## SINGULAR POINTS

### Window sill

The sill is treated using a metal flashing which must have a fallout in front of the terracotta of 30mm and must protrude 20 mm from the Piterak® Slim.



### Lintel

The lintel is treated with a metal flashing. The Piterak® Slim is used in the same way than for the starting part.

A space of 10 mm is required between the flashing and the bottom of the Piterak® Slim above the lintel

### Jamb

In jambs, returns are treated with metal profiles (angles, ..). A space of 10 to 20 mm is required between the profile and the ends of the Piterak® Slim.

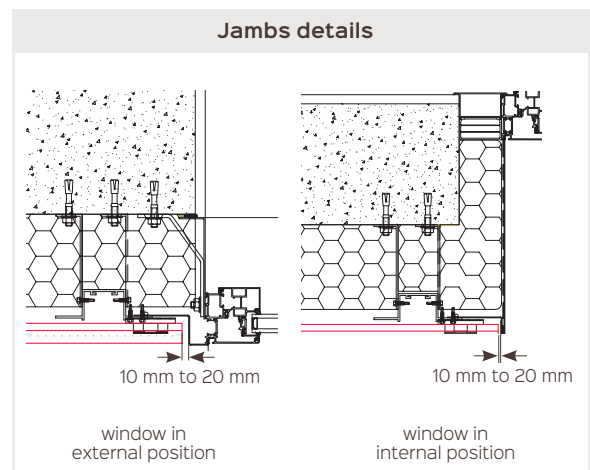
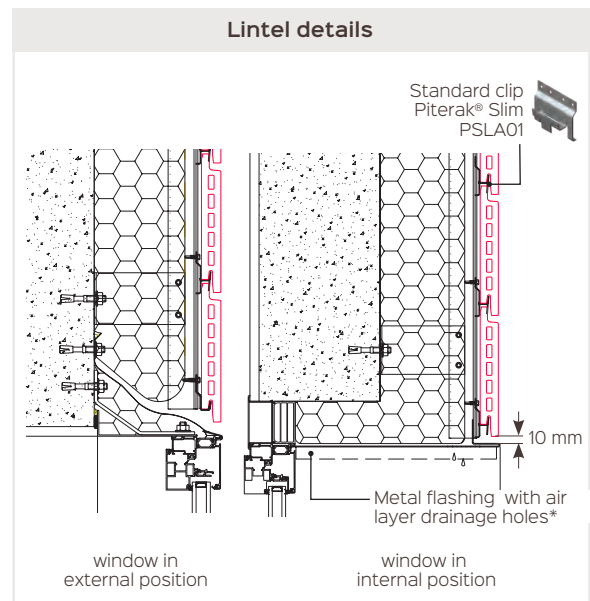
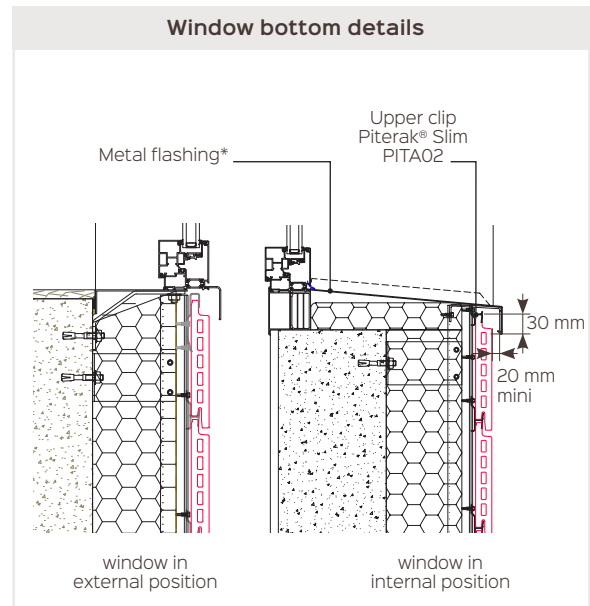

\*Not provided by Terreal

# Horizontal fitting guide

## External angle with profile

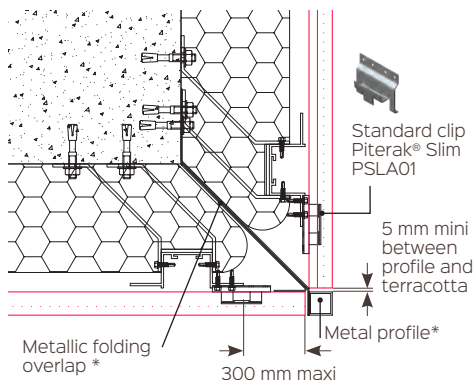

## External angle with miter cut

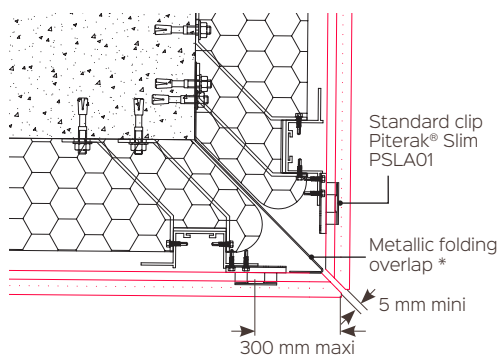

## Internal angle

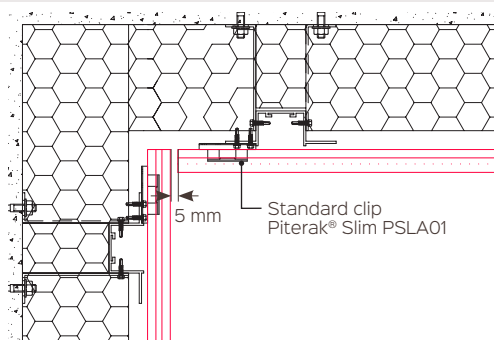

## SINGULAR POINTS

### External angle

#### With profile

A metal profile (generally powder coated, not sold by Terreal) handles the angle. This profile can be either recessed or flush with the front face of the facade. In all cases a space of 5 mm is required between the profile and the ends of Piterak® Slim.

#### Without profile

Piterak® Slim are cut at one end on the edge of the product. The cutting angle is 45° and a 5 mm dish is kept (miter cut).

### Internal Angle

Inside corners are treated with standard products. A space of 2 to 5 mm is required between Piterak® Slim.

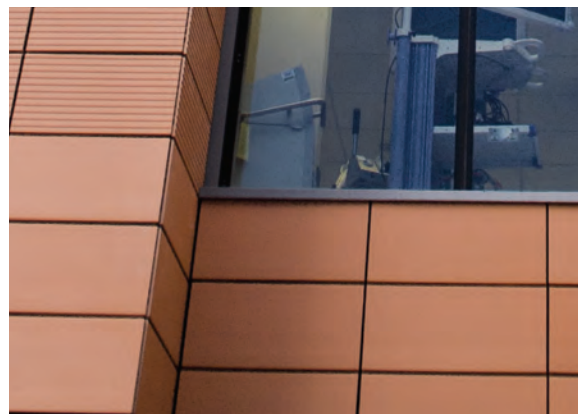

\*Not provided by Terreal

## SINGULAR POINTS

### Frame splitting

The vertical profiles being mounted in a clamped manner (no sliding points) it is necessary to have a space between each profile. This allows to absorb aluminum expansions induced by thermal variations. This can be used with or without using a flashing metal.

#### Without flashing metal

Frame splitting can be done without flashing metal. In this case, a space should be left between 2 profiles at least 8 mm.

In no case should the Piterak® Slim be bridged on 2 consecutive vertical profiles.



Never bridge a product on 2 consecutive profiles.

### Expansion joint

The space to be kept between 2 adjacent Piterak® Slim, is at least the thickness of the expansion joint with a minimum of 20mm.

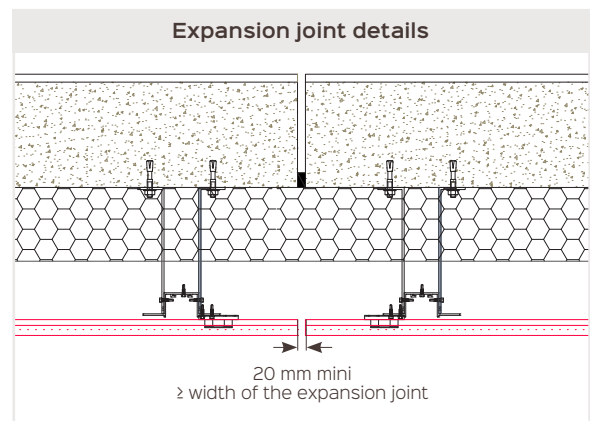
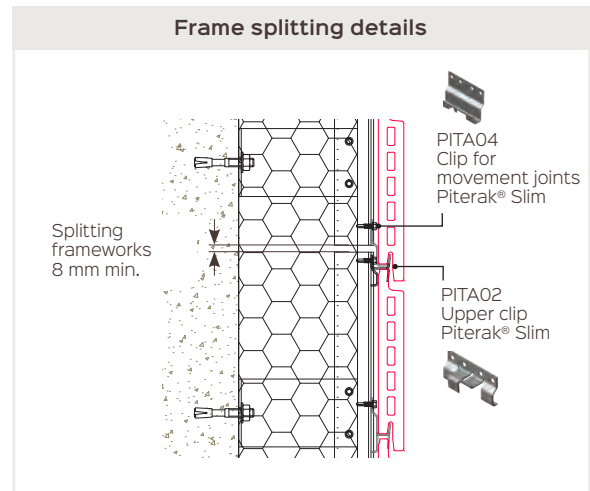

*\*Not provided by Terreal*

# Soffit fitting guide

## SYSTEM DESCRIPTION

Soffit fitting guide Cladding process based on 30 mm thick double-wall terracotta products (~48,5 kg / m<sup>2</sup>), Piterak® Slim can be fixed in a soffit detail secured using special clips, to a vertical steel framework secured to the main structure.

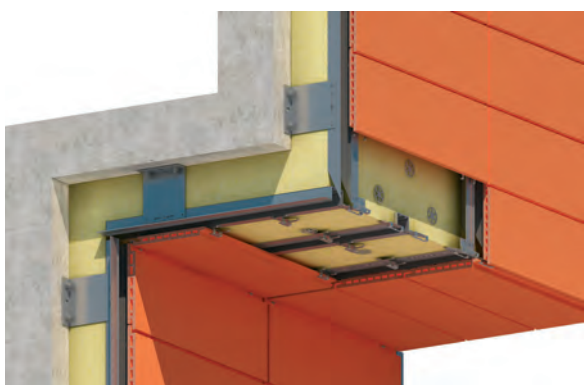

Soffit installation is permitted for the Piterak® Slim system on horizontal concrete walls (more than 3 m from the ground), with no playground nearby, respecting the following recommendations:

- Add an intermediate profile at mid-length as well than 2 additional clips
- The brackets are doubled
- The supporting framework of the soffit must be independent from the façade works.
- The installation of the elements on the soffit is done from the outside to the inside of the building.
- Installation inclined > 30 ° or on the soffit is limited to maximum terracotta size 400 x 1,500 mm.



Maximum size: 400 x 1500 mm  
Intermediate framework + 2 additional clips per Piterak® Slim.  
Installation permitted on + 3m walls inaccessible.

## PROPERTIES

### Support type:

- Concrete wall
- Coated masonry

### Certifications:

Product under technical assesment : n°2.2 / 13-1584 V1.



### Wind resistance:

		MODULE LENGTH UP TO 1510 MM
MODULE HEIGHT (MM)	200	1467 Pa
	250	
	300	
	400	985 Pa



ZOOM ON ...

Installation guide  
video

[www.youtube.com/user/terrealvideos](http://www.youtube.com/user/terrealvideos)



## INSTALLATION

Installation from the outside to the inside of the wall.  
Install the PITA04 clip then position the products until it stops at the notch.

The following products are attached using clip PSLA01.

The last element is fixed with a PITA02 upper clip.

As a reminder, the clip of the profile at mid span are doubled.

To ensure continuity with the non-inclined facade or soffit, cut the bevel profiles and start the installation with PITA04 clip.

Wind permissible depressions are shown (see p21).

The 20 mm air gap should be kept behind each product.

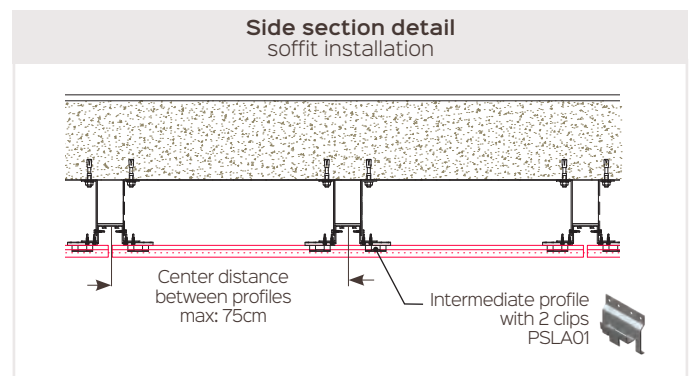
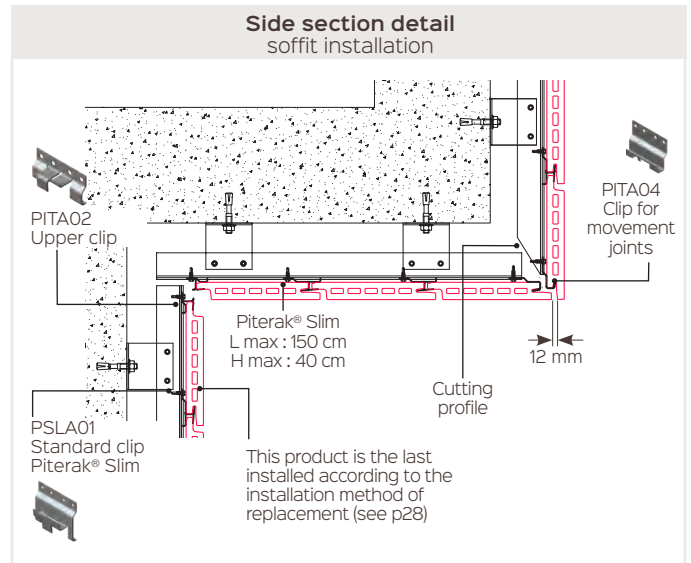

# Wood frame wall fitting guide

## SYSTEM DESCRIPTION

Cladding process based on 30 mm thick double-wall terracotta products (~48,5 kg / m<sup>2</sup>), Piterak® Slim can be installed on wooden framework on a composite framework with profiles with center distance of 645 mm maximum located to the right of the timber frame wall uprights and respecting the following recommendations:

- Reserve a minimum 20 mm air space between the wall and siding. Check with local industry standards as minimum air gap above 20mm varies from Country to Country.
- Length of vertical aluminum profiles limited to 3m.
- The layout must take into account the center distance of the uprights of the timber frame wall.
- The vertical profiles must be fixed to the right of rafters.
- The support wall must comply with NF DTU 31.2.



Installation on wooden frame wall in accordance with NF DTU 31.2, is limited to: **Maximum height of 18 m** (+ point gable) in wind zones 1, 2 and 3 in situations a, b and c, maximum height 10 m (+ pinion point) in situation d.

**Check with local industry standards and local guidelines as requirements varies from Country to Country.**

## PROPERTIES

### Support type:

- Wood frame wall (according to NF DTU 31.2) up to 18 m with special provisions for openings from 9 m to 18 m.

### Certifications:

Technical advice for horizontal installation n° 2.2/13-1584 V1.



### Impact resistance:

Highest (Q4) impact resistance rating under French CSTB for standard finishes.

Without CSTB test, ridged and grooved finishes are rated Q3.

### Wind resistance:

		STANDARD INSTALLATION		REINFORCED INSTALLATION*
		Module length (mm)		
		1530	Up to 1810	Up to 1810
MODULE HEIGHT (MM)	200	1936 Pa		
	250	2219 Pa	986 Pa	1947 Pa
	300	2359 Pa		
	400	1465 Pa		
	500		962 Pa	Not tested
	600	962 Pa		

\* Reinforced installation with 1 intermediate profile and 2 adding clips.

## INSTALLATION

A waterproofing membrane conforming to NF DTU 31.2 must be placed on the outside of the wall of the timber frame wall.

With the joints open, the rain screen will have a UV resistance of 5000 h according to standard NF EN 13589-2. In situations a, b and c, the bracing panels of the timber frame wall can be positioned on the inside or outside of the wall. In situation d, if the bracing panels of the wooden frame wall have been positioned on the inside of the wall, wood-based panels must be positioned on the outside of the wall.

The rain screen is cut every 6 m to evacuate surface runoff water. Under no circumstances should the rain screen be placed against the cladding product (air gap of 20 mm minimum).

The profiles are attached to the uprights of the timber frame wall using wood screws of minimum dimension Ø 7 x 50 mm.

PK pullout resistance characteristic is 598 daN for an anchoring of 50 mm in a wooden support.

Each clip is fixed to the right of the omega profiles using 2 self-drilling screws 5.5 x 22 mm. Only the omega profiles are compatible with installation on a wooden frame wall. The frame is split on each floor. Bridging of junctions between successive uprights by shingles is excluded.

The figures illustrate the minimum installation arrangements on the timber frame wall. Situations a, b, c and d are defined in NF DTU 20.1.



**Check with local industry standards and local guidelines as requirements varies from Country to Country.**

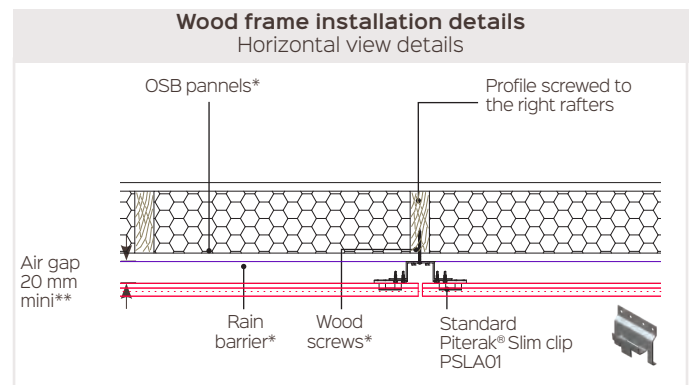
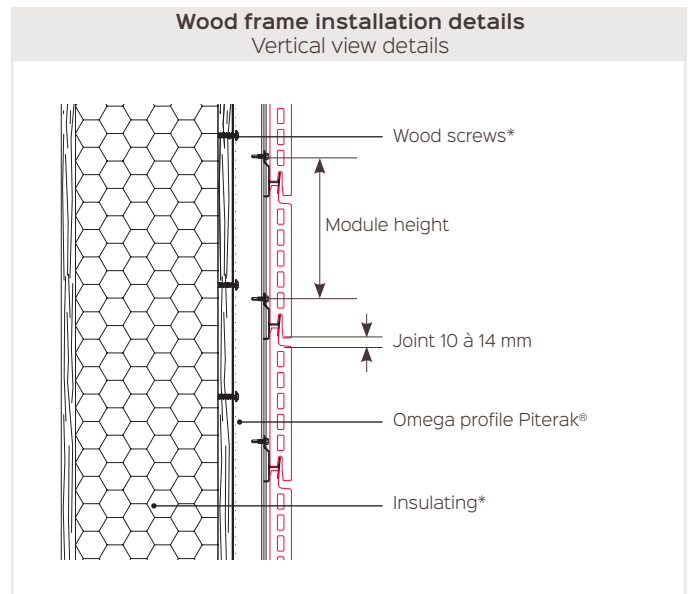

\*\* Check with local industry standards as minimum air gap above 20mm varies from Country to Country

# Wood frame wall fitting guide

## Wood frame installation Window bottom details

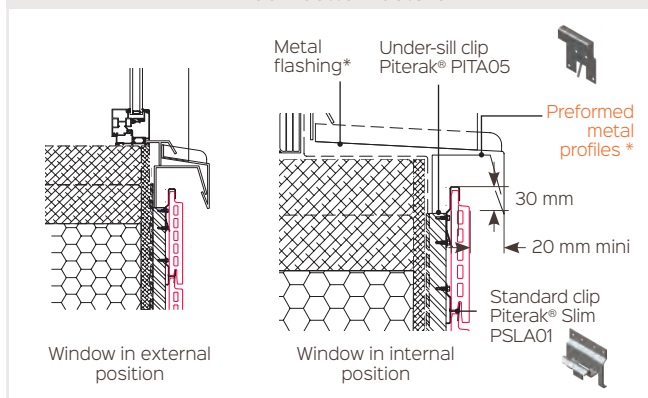

## SINGULAR POINTS

### Window bottom details

The sill is treated using a metal flashing which must have a fallout in front of the terracotta of 30 mm and must protrude 20 mm from the Piterak® Slim.

### Lintel details

The lintel is treated with a metal flashing. The Piterak® Slim is used in the same way than for the starting part.

A space of 10 mm is required between the flashing and the bottom of the Piterak® Slim above the lintel

### Jambs details

In jambs, returns are treated with metal profiles (angles, ...). A space of 10 to 20 mm is required between the profile and the ends of the Piterak® Slim.

## Wood frame installation Lintel details

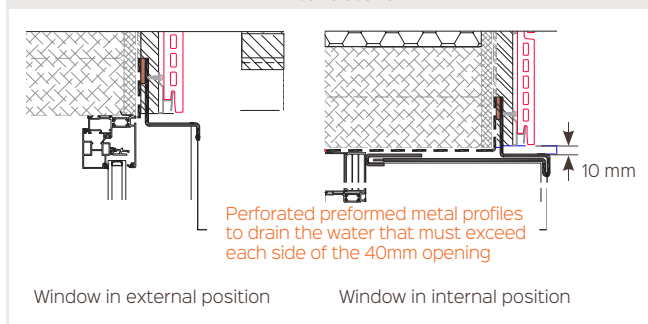

### Specificity for building :

- from 10 to 18 m high (+ gable end) in situations a, b and c.
- from 6 to 10 m high (+ pinion point) in situation d.

### Implementation with:

- Ear flaps in preformed metal profiles extended beyond the vertical plane of the facing
- Preformed metal lintel profiles extended 40 mm beyond the bay tables
- Preformed metal profiles on the boards berries.

## Wood frame installation Jambs details

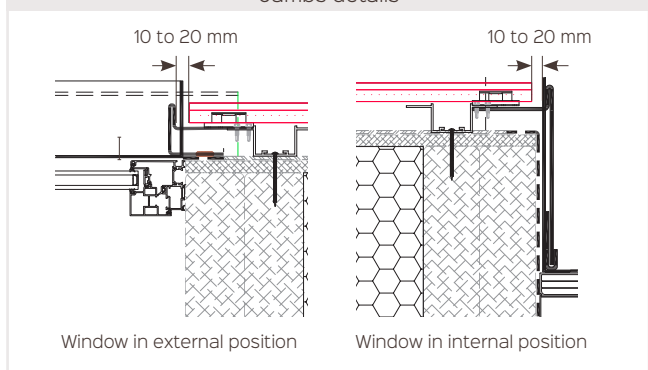

### Corners

Piterak® Slim are cut at one end on the edge of the product. The cutting angle is 45° and a 5 mm dish is kept (miter cut)



**Check with local industry standards and local guidelines as requirements varies from Country to Country.**

## Wood frame installation Corner with miter cut

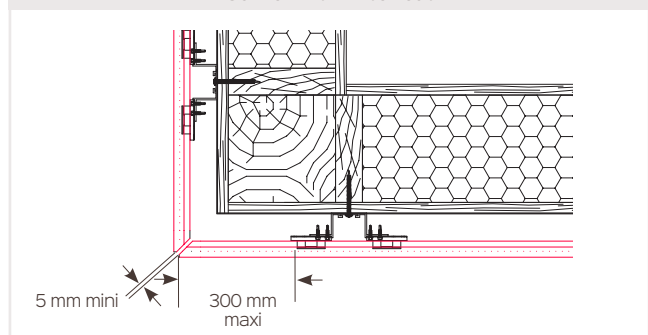

\*Not provide by Terreal



# Seismic zone installation

Piterak® Slim 20 to 60 x 180 cm can be used in seismic zones:

- Omega profile linked each other
- Bracket Isolco C2 depthness 50 to 240 mm

SEISMIC TEST	FREQUENCY (HZ)	NUMBER OF CYCLE	AMPLITUDE (MM)	ACCELERATION (M/S <sup>2</sup> )	PASSED
Parallelogram test	0,2 ≤ f ≤ 1 Hz	20	± 60 mm	-	✓
Test in the plane of the support	3	10	± 46,4 mm	16,5	✓
	4,3 Damped natural frequency	5	± 22,6 mm	16,5	✓
Test perpendicular to the plane of the support	3	20	± 1,9 mm	16,5	✓
	15	20	± 1,9 mm	16,5	✓

No seismic test for 15, 20 and 60 cm height Products.

## CONCRETE WALL

### Profiles

Installation in seismic zone only with Omega profile and brackets (ISOLCO up to 240 mm)

Omega profiles are joined to each other by an aluminum profile fixed on the back of the omega profiles.

The vertical center distance of the L profile is 100 cm maximum.

### Isolco brackets up to 240 mm maximum

The brackets are doubled (in opposition). The spacing vertical between the brackets is 100 cm maximum.

### Load-bearing structures

The load-bearing structures are split every levels. Piterak® Slim must not be bridged between 2 levels.

### Anchoring the brackets

On concrete wall (NF DTU 23.1), the anchoring of the brackets is made using A4 plugs type FM 753 CRACK Ø 12.

## WOOD FRAME WALL

### Profiles

Installation in a seismic zone on a wooden frame wall with direct installation of the profiles on the rafters of the wood frame wall.

The omega profiles are directly fixed to the right of the rafters with lag bolts type TH 13 ZN.

### Load-bearing structures

The load-bearing structures are divided at all levels. Piterak® Slim must not be bridged between 2 levels.

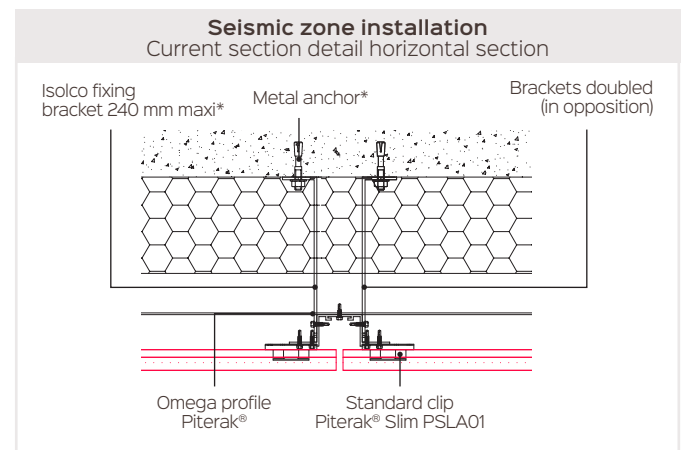
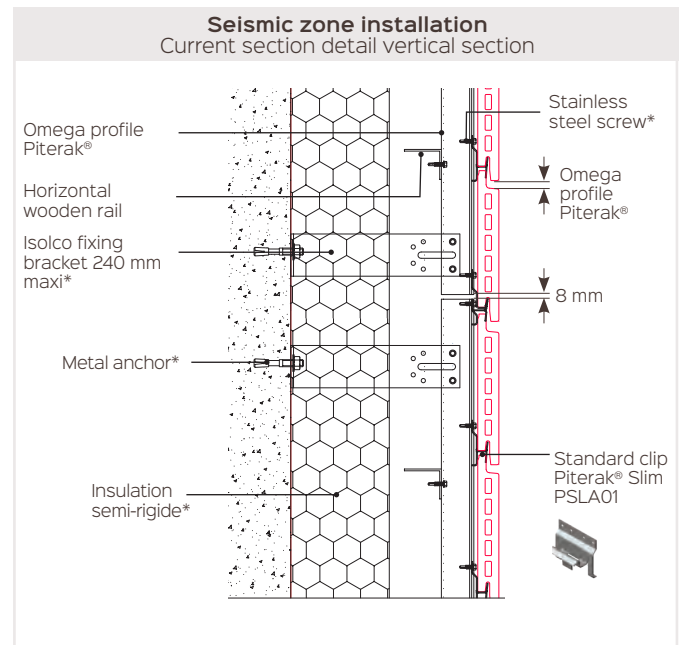

### Concrete wall installation:

- Installation in seismic zone with omega profile only
- Bracket up to 240 mm max.
- Max vertical center distance. L profiles: 100cm
- Double brackets (in opposition)
- Load-bearing frame split at each level

### Wood frame wall installation:

- Installation in seismic zone with omega profile only
- Load-bearing frame split at each level

\*Not provided by Terreal



# Seismic zone installation

## SINGULAR POINTS

### Corners

At each corner exiting the 40/10th steel side stops must be positioned.

Installation of mitered angles in seismic installation is not referred to in the technical opinion.

### Expansion joint

In front of the expansion joints, bridging of the joint with terracotta is excluded and a folded profile device must be implemented so that it protects the insulation while absorbing the differential movements due to the expansion joints.

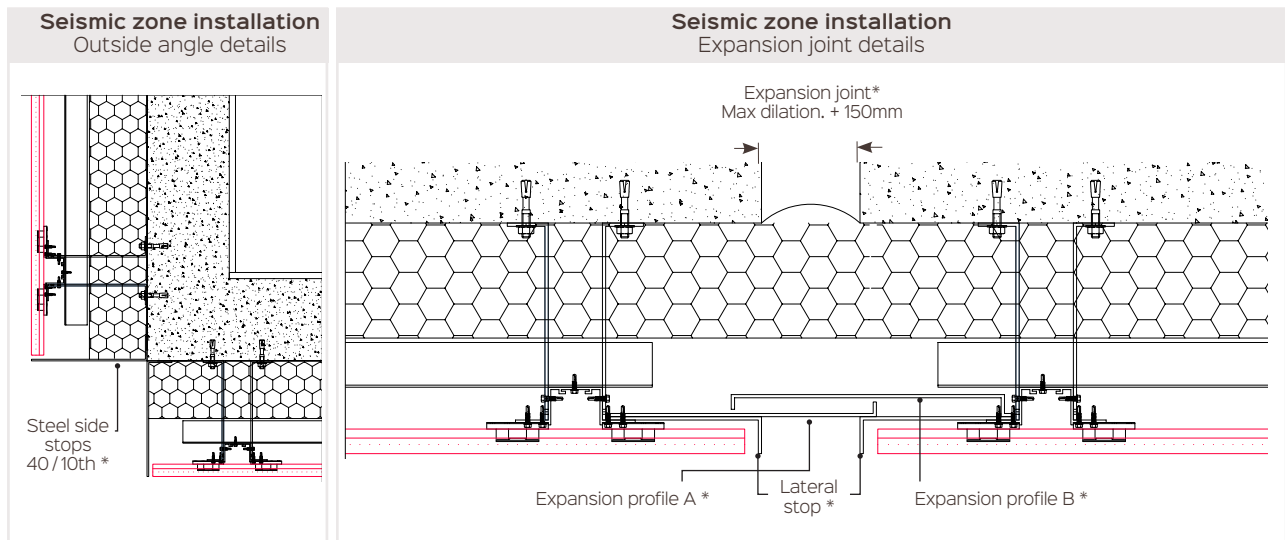

### Lateral stop

A lateral stop must be implemented every 4 frames (4x180 cm or 7.3 m maximum) using metal profiles fixed to the vertical profiles.  
Example: 4 x 180 cm or 7.2 m maximum.

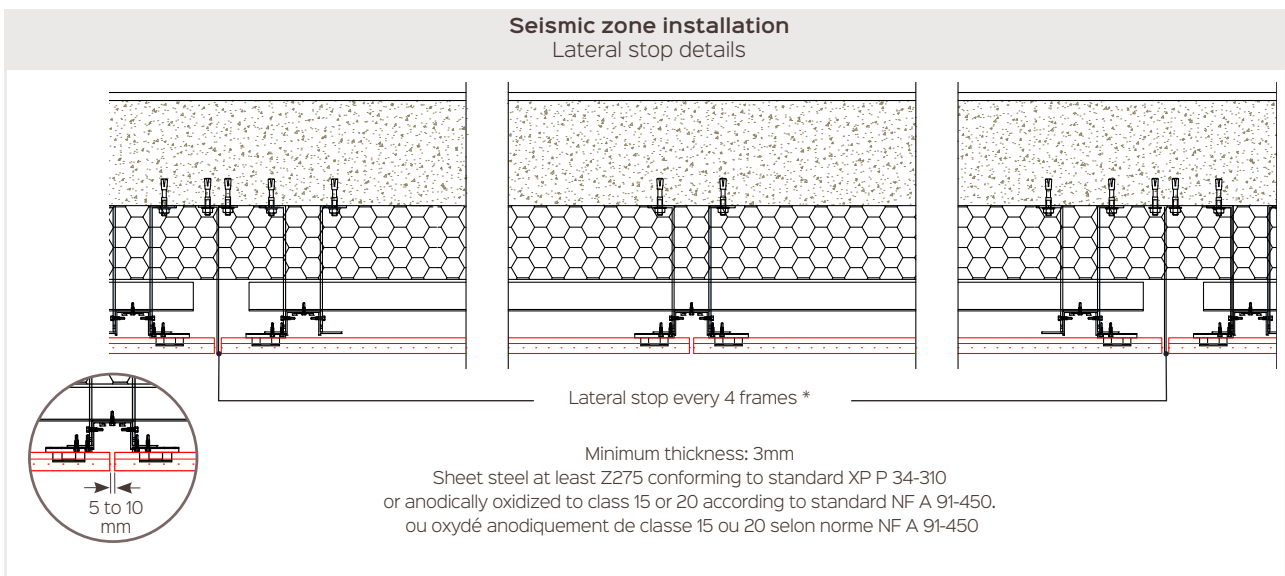

\*Not provided by Terreal

# Replacement Guide



Broken product.



Remove the broken product.



Locate the positioning of the 2 visible common clips.



Remove the 1<sup>st</sup> clip.



Remove the 2<sup>d</sup> clip.



Install the high clip PITA02.



Trace the cutting area on the upper part of the replacement product. The cutting of the product in the upper part is necessary in order to be able to fit the cut area in the upper clip.

Cut out each side of the Piterak® Slim.

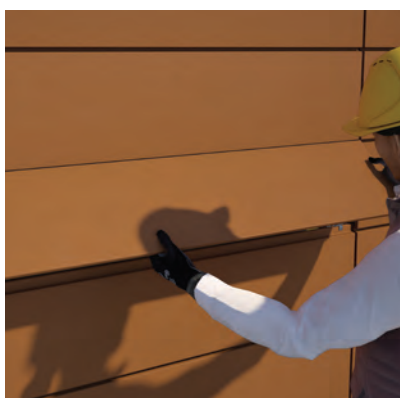

Put the replacement product in place by first inserting the upper part, pushing towards the wall then exerting downward pressure to position it at the bottom of the clips.



The product is replaced.

# V-clip<sup>®</sup> vertical installation system

## SYSTEM DESCRIPTION

Cladding process based on 30 mm thick double-wall terracotta products (~48,5 kg / m<sup>2</sup>), the Piterak<sup>®</sup> Slim can be installed vertically using the specific V-clip<sup>®</sup> system (Façade Label).

V-clip<sup>®</sup> system is a fastening system consisting of a high-performance steel wire clip that snaps onto a horizontal rail. It allows vertical fixing even on curved surfaces.

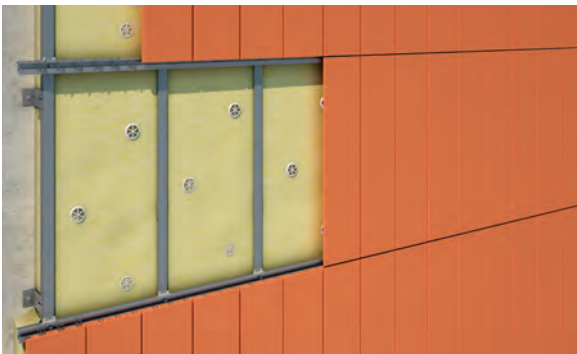

## FIXING ACCESSORIES

Accessories sold by Terreal:



VCA01  
V-clip<sup>®</sup> TS11  
SAP 132182



VCV01  
Stainless steel screw  
inox  
SAP 132186



VCV02  
Wood screws  
SAP 152359

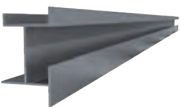

VCP01  
Support rail for joints 8 mm  
(seismic pose)  
SAP 132184



VCC01  
Polypropylene spacer  
SAP 132183



VCP03  
Support rail for  
joints 8 mm  
SAP 147016



VCC02  
Seismic plastic shim  
or 5 mm vertical joint  
adjustment  
SAP 132185



VCE01  
Splint for expansion  
joint  
SAP 132187

The other supplies necessary for vertical installation are not offered by Terreal: dowels, brackets, L-shaped profile or tube, insulation, bay cladding profile, splinting flap air blade, .... They are the responsibility of the fitting company.

## PROPERTIES

### Supporting walls

- NF DTU 23.1 concrete wall (flat and curved wall)
- NF DTU 20.1 coated traditional masonry
- NF DTU 31.2 wood frame wall (9m max.)

### Certifications

Technical advice for vertical installation n° 2 / 13-1542 \* V2



### Impact resistance:

Highest (Q4) impact resistance rating under French CSTB for 30 cm module in standard finish.

Without CSTB test, ridged and grooved finishes are rated Q3.



At least 4 V-clip<sup>®</sup> per terracotta product (2 at the top and 2 at the bottom).

Check that each clip in the lower part of the product does not take up more than 8 kg of load each.

### Seismic installation

In seismic configurations:

- vertical profiles must be tubes
- the brackets are replaced by stirrups
- the seismic plastic shim is systematically used
- the support wall is made of sheet concrete
- the product will be maximum 600 x 1500 mm

(Results obtained following additional tests at French CSTB)

# V-clip® vertical installation system



## DESIGN RULES OF AVIS TECHNIQUE (CSTB)

Determining the calculation of the number of V-clip® required by Piterak® Slim depends on the format of the terracotta product as well as the desired wind resistance.

At least 2 V-clip® / edge is needed, or 4 V-clip® per product.

It will therefore be checked first if 2 V-clip® are enough to support the product in the lower part from the following formula :

$$N = (b \times L \times 48,5) / 8$$

with b = module width and L = length of the Piterak® Slim expressed in m (48.5 being the surface mass of Piterak® Slim).

- If  $N < 2$  then 2 V-clip® in the lower part and 2 V-clip® in upper part are required so 4 V-clip® / Piterak® Slim
- If  $N > 2$  then consider rounding up to obtain the number of V-clip® at the bottom and  $2 \times N$  for the total of V-clip® by Piterak® Slim

For example if the calculation gives  $N = 2.4$ : we must consider  $N = 3$  V-clip® in the lower part. So  $2 \times 3 = 6$  V-clip® by Piterak® Slim.

## WIND RESISTANCE

Depending on the number of V-clips® calculated for the weight gain of the Piterak® Slim, it should be checked whether this is sufficient to satisfy the desired wind resistance value.

The admissible wind pressure according to the number N of V-clip® / Rive is given by the formula below :

$$P = Ra / (0,5 \times K \times L \times b / (N - 1))$$

P: admissible pressure in Pa under normal wind (according to NV65 rules modified).

Ra: admissible resistance to the right of the hooks  $Ra = 80$  N (8 daN).

L: length in m of the terracotta element.

b: width in m of the terracotta element.

N: the number of V-Clip® per bank.

K: coefficient given below :

N (V-clip®/edge)	2	3	4	5	6 and more
K	0,5	1,25	1,1	1,14	1,13

### Examples

#### Piterak® Slim 200 x 1520 mm

$$b = 0,2 \text{ m} ; L = 1,52 \text{ m}$$

$$N = (0,2 \times 1,52 \times 48,5) / 8 = 1,84$$

$$N = 2 \text{ V-clip® in the lower part}$$

$$(4 \text{ V-clip® per Piterak® Slim } 20 \times 152 \text{ cm})$$

$$K = 0,5$$

$$P = 80 / (0,5 \times 0,5 \times 0,2 \times 152 / (2 - 1)) = 1052 \text{ Pa}$$

### Other examples

L X b	V-CLIP® TS 11 QUANTITY	ELIGIBLE DEPRESSION
200 x 1520 mm	2 / rive	1050 Pa
250 x 1300 mm	2 / rive	980 Pa
300 x 1000 mm	2 / rive	1066 Pa

### Special cases

Table giving the maximum lengths with 2 V-clip® in the lower part and 2 V-clip® in the upper part of Piterak® Slim

b	2 V-CLIP® / EDGE (4 / PRODUCT)		NUMBER OF V-CLIP®	360 CM RAIL
	L max	Vent max		
0,2 m	1,65 m	969 Pa	12,1 / m²	0,17 cm / m²
0,25 m	1,32 m	969 Pa	12,1 / m²	0,21 cm / m²
0,3 m	1,1 m	969 Pa	12,1 / m²	0,25 cm / m²
0,4 m	0,83 m	969 Pa	12 / m²	0,33 cm / m²
0,5 m	0,66 m	969 Pa	12,1 / m²	0,42 cm / m²
0,6 m	0,55 m	969 Pa	12,1 / m²	0,51 cm / m²

Table giving the maximum number of V-clip® at the bottom for the maximum possible length, ie 1800 mm.

(Results obtained following additional tests at Frensh CSTB)

b	NB. MAX V-CLIP®	L MAX	WIND MIN. WITH NB. MAX. V-CLIP® / PRODUCT	V-CLIP® / M²	360 CM RAIL
0,2 m	3 / edge	1,8 m	711 Pa	11,1 m	0,15 m²
0,25 m	3 / edge	1,8 m	569 Pa	8,9 m	0,15 m²
0,3 m	4 / edge	1,8 m	808 Pa	7,4 m	0,15 m²
0,4 m	6 / edge	1,8 m	983 Pa	5,6 m	0,15 m²
0,5 m	7 / edge	1,8 m	944 Pa	4,4 m	0,15 m²
0,6 m	8 / edge	1,8 m	918 Pa	3,7 m	0,15 m²



## DESIGN RULES OF BBA

Design Rule for number of V clip per product according to the standard BS EN 1991-1-4:2005 and its UK National Annex. The quantity of V-clip is determined in order to satisfy this ratio below:

Minimum of 4 V-clip per product (2 per side)

$$\frac{F_h}{R_h} + \frac{F_v}{R_v} \leq 1$$

F<sub>h</sub> = Wind design load value in Newton

R<sub>h</sub> = Vclip horizontal resistance value (**80 Newton**) x number of V-clip in unit

F<sub>v</sub> = Dead load value in Newton (weight of the product)

R<sub>v</sub> = Vclip vertical resistance value (**80 Newton**) x number of bottom V-clip in unit

Design resistances of the V-clip® fasteners

V-CLIP® FASTENER TYPE	MINIMUM SKIN THICKNESS OF PINCHING PANEL (MM)	DESIGN RESISTANCE (N)	
		HORIZONTAL LOAD*	VERTICAL LOAD**
		WITH GROOVED / HOLLOW CORE TERRACOTTA OR NATURAL STONE PANEL	
N°9	8,5		
N°11	9,9	80	80
N°13	12,3		

\* Use of the above resistances produces a partial safety factor on clip strength of 4.

\*\* Use of the above resistances produces a partial safety factor on clip strength of 5. The vertical load of the tile is carried by the clips on the bottom edge of each tile.

### Example 1

#### Piterak® Slim 300 x 1000 mm

Weight 48,5kg/m<sup>2</sup>  
Wind design load : 900 Pa

NB. V-CLIP® PER PRODUCT	4	6	8
F <sub>h</sub> (N)	270	270	270
R <sub>h</sub> (N)	320	480	640
F <sub>v</sub> (N)	145,5	145,5	145,5
R <sub>v</sub> (N)	160	240	320
F <sub>h</sub> /R <sub>h</sub> + F <sub>v</sub> /R <sub>v</sub>	1,75	1,17	0,88

In this case, we need to use 8 V-clip per product

### Example 2

#### Piterak® Slim 600 x 1000 mm

Weight 48,5kg/m<sup>2</sup>  
Wind design load : 1100 Pa

NB. V-CLIP® PER PRODUCT	4	6	8	10	12	14	16
F <sub>h</sub> (N)	660	660	660	660	660	660	660
R <sub>h</sub> (N)	320	480	640	800	960	1120	1280
F <sub>v</sub> (N)	291	291	291	291	291	291	291
R <sub>v</sub> (N)	160	240	320	400	480	560	640
F <sub>h</sub> /R <sub>h</sub> + F <sub>v</sub> /R <sub>v</sub>	3,88	2,59	1,94	1,55	1,29	1,11	0,97

In this case, we need to use 16 V-clip per product

# V-clip® vertical installation system

## PRIOR RECOMMENDATIONS

The implementation of vertical profiles must comply with the rules of the technical assessment : French CSTB n ° 2/13-1542 \* V2

The layout is carried out beforehand by the company, in order to determine the positioning of the vertical profiles as well as the dimensions of the Piterak® Slim.

To define the horizontal layout correctly it is advisable to maintain a vertical space of 10 mm between 2 products.

## IMPLEMENTATION

The vertical profiles are fixed to the walls by means of angle brackets (or stirrups) fixed to the profile by self-drilling stainless steel screws. Thus fixed this framework is said to be "restrained".

The maximum distance between the vertical frames is 60 cm.

Attach the horizontal rail (VCP02) to the vertical frame using self-drilling screws (VCV01). Insert the splint for expansion joint (VCE01) in the rail before fixing the next rail.

Attach the splint to the vertical profile. Place the V-clips® in the lower and upper holes of the product (number of clips according to product format).

Present the fitted Piterak® Slim product and clip the V-clip® low to the rail.

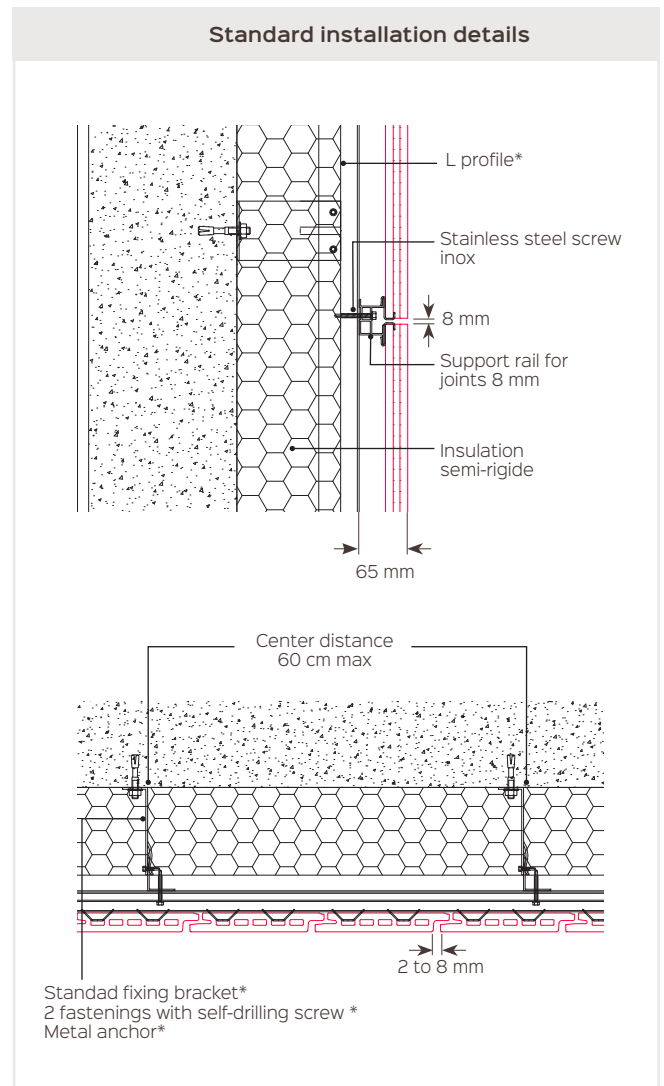

ZOOM ON ...

Installation  
guide video

[www.youtube.com/user/terrealvideos](http://www.youtube.com/user/terrealvideos)

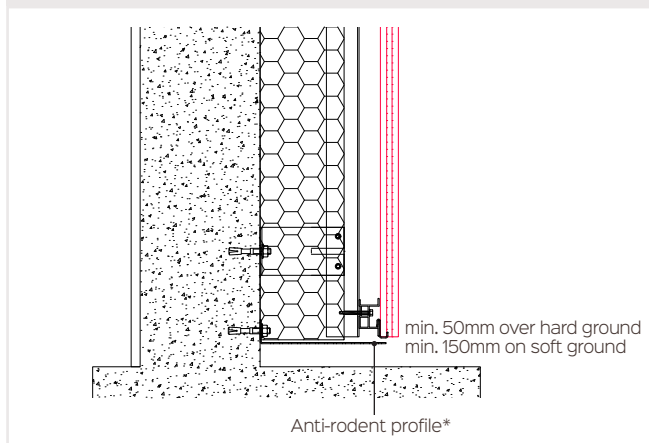
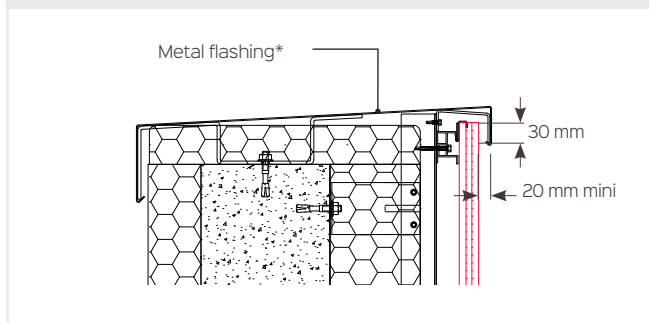

\*Not provided by Terreal

**Bottom detail****Top detail**

## SINGULAR POINTS

**Bottom details**

In the lower part, it is necessary to respect a minimum height between the ground and the bottom of the starting Piterak® Slim element.

- Height is 50 mm on hard ground or 150 mm on soft ground for application on concrete wall or traditional coated masonry.
- Height of 200 mm whatever the type of floor for a wood frame wall installation.

**Top details**

A metal capping must be placed in the upper part or parapet to limit the penetration of rainwater.

- The metal capping must have a fall in front of the terracotta of 30 mm and must overhang the Piterak® Slim by at least 20 mm.
- Thus dimensioned, this capping prevents rainwater from flowing directly onto the Piterak® Slim and allows good ventilation of the air gap. A regular flow of water promotes the appearance of foam on the products: this degrades the aesthetics of the facade and results in a need of regular cleaning operation.



# V-clip® vertical installation system

## SINGULAR POINTS

### External angles

2 options are possible for managing external angles :

*Option 1* : The angles are treated with standard products. A joint of at least 5 mm must be kept between the ends of the products.

*Option 2* : the cover of one of the products is cut. A joint of at least 5 mm must be kept between the ends of the products.

The overhang of the horizontal rail is 250 mm maximum.

### Internal angle

The Internal corner are treated with standard products. A space of 6mm is required between the ends of the Piterak® Slim.

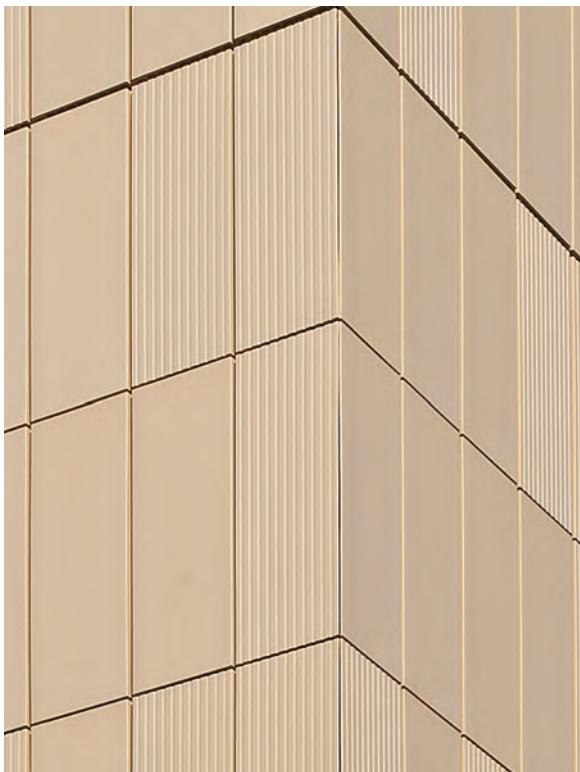

External angles details

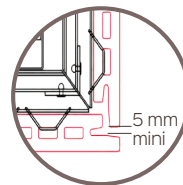
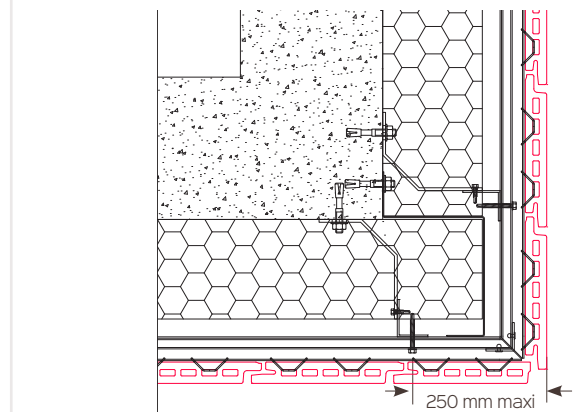

option 1

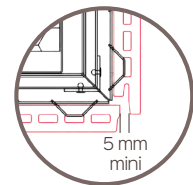

option 2

Internal angle details

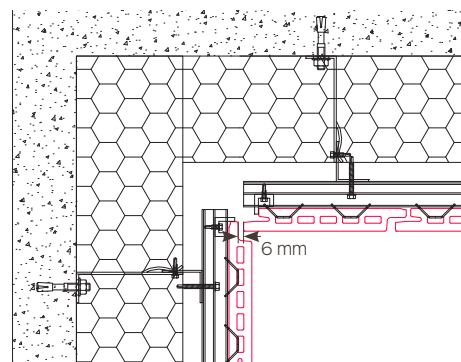

### Window sill detail

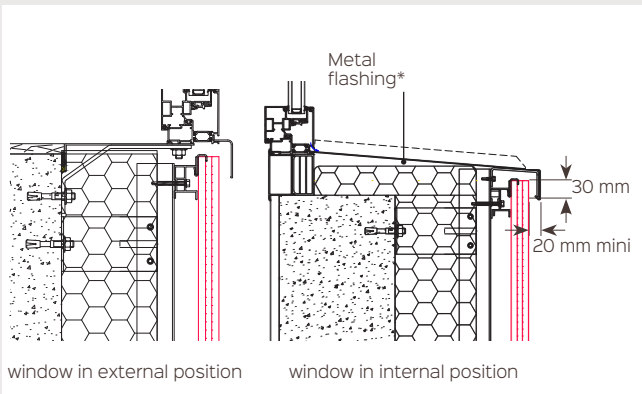

## SINGULAR POINTS

### Window sill

The sill is treated using a metal flashing which must have a fallout in front of the terracotta of 30 mm and must protrude 20 mm from the Piterak® Slim.

### Lintel

The lintel is treated with a metal flashing. The Piterak® Slim is used in the same way than for the starting part. A space of 10 mm is required between the flashing and the bottom of the Piterak® Slim above the lintel

### Jamb

In jambs, returns are treated with metal profiles (angles, ..) A space of 10 to 20 mm is required between the profile and the ends of the Piterak® Slim.

### Lintel details

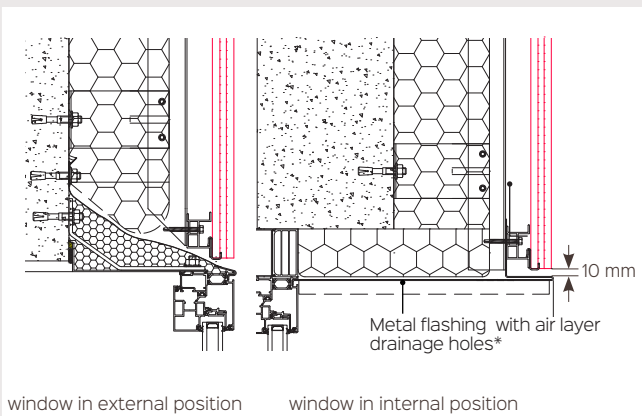

### Jambs details

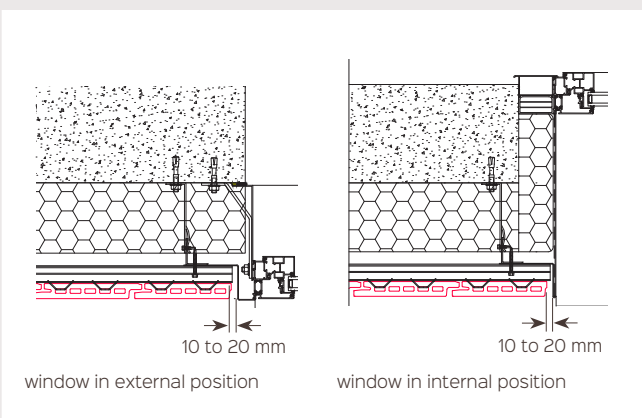

# V-clip® vertical installation system

## SEISMIC ZONE INSTALLATION

SEISMIC TEST	FREQUENCY (HZ)	NUMBER OF CYCLE	AMPLITUDE (MM)	ACCELERATION (M/S <sup>2</sup> )	PASSED
Parallelogramm test	0,2 ≤ f ≤ 1 Hz	20	± 60 mm	-	✓
Test in the plane of the support	3	10	± 46,4 mm	16,5	✓
	7,8 Damped natural frequency	5	± 6,9 mm	16,5	✓
	15	10	± 1,9 mm	16,5	✓
Test perpendicular to the plane of the support	3	20	± 26,4 mm	9,3	✓
	15	20	± 1,6 mm	9,3	✓

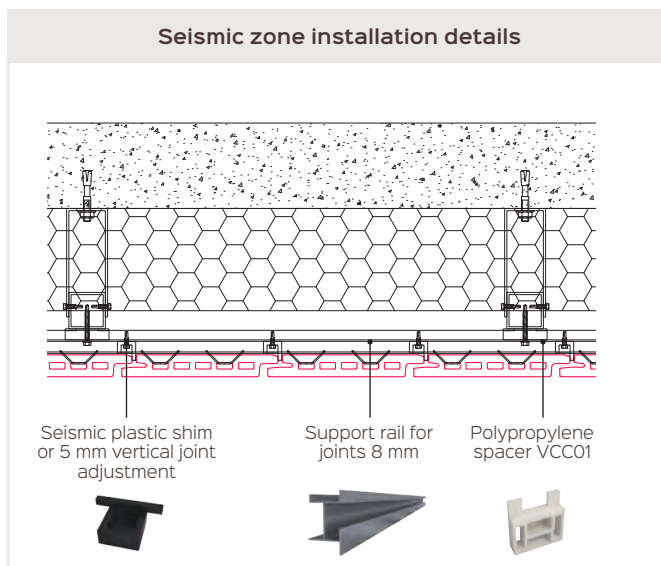

Piterak® Slim 20 20 up to 60 x 150 cm can be used in seismic zones WITH V6clip system:

- Steel bracket depthness up to 260 mm thickness 3 mm

For a construction in a seismic zone, it is necessary to use the support rail VCP01 as well as the polypropylene spacers VCC01.

The vertical profiles are fixed to the walls by means of angle brackets (or stirrups) fixed to the profile by self-drilling stainless steel screws. Thus fixed this framework is said to be "restrained".

The maximum distance between the vertical frames is 60 cm.

The 1<sup>st</sup> step is the preparation of the support rails (VCP01).

- Polypropylene spacers must be placed at the rear of the rail, spaced apart according to the center distance of the profiles (the spacers must be aligned with the profiles once the rail is fixed).
- Simultaneously drill the support rail and the polypropylene spacers (to avoid the deposit of chips between the main frame and the shim).

Then fix the horizontal rail (VCP01) to the vertical frame using self-drilling screws (VCV01). Insert the splint (VCE01) in the rail before fixing the next rail. Attach the fishplate to the vertical profile.

Place the V-clips® in the lower and upper holes of the product (number of clips depending on the format of the product). Present the fitted Piterak® Slim product and clip the low V-clips® to the rail.

Insert the seismic block (VCC02) in the bottom horizontal rail and fix it with a self-drilling screw then present the second product. Repeat the operation.

\*Not provided by Terreal

# Replacement Guide

## Vertical installation with V-clip®



Broken product.



Remove the broken product.



Install the V-clip® on the lower part of the replacement terracotta product. Place the terracotta product by clipping the V-clips® on the bottom rail.



Install the waiting V-clips® on the upper rail, where the cells will be positioned. Make a rocking movement to advance the terracotta product towards the high clips.



Using a flat screwdriver or similar object (with plastic protection **i.e such as electrical tape wrapped onto the flat blade** so as not to chip the terracotta), lift each clip one by one to put them on hold on the full edge of the product. Then press on the product to permanently engage the V-clips® in the cells.



Check the alignment of the installed product and the stability.

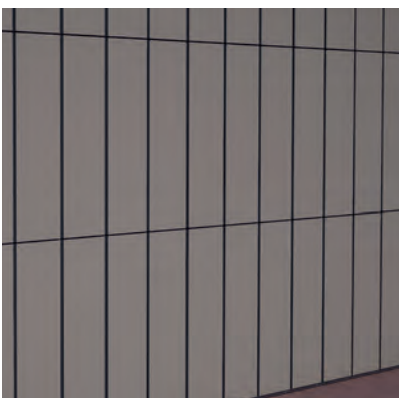

The product is replaced.

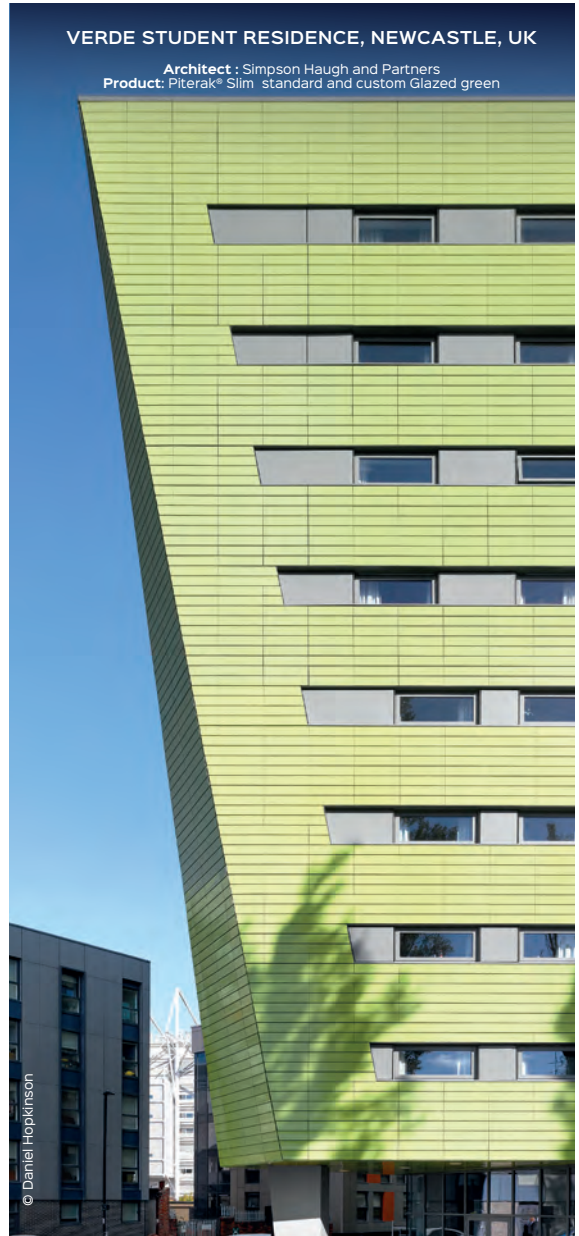

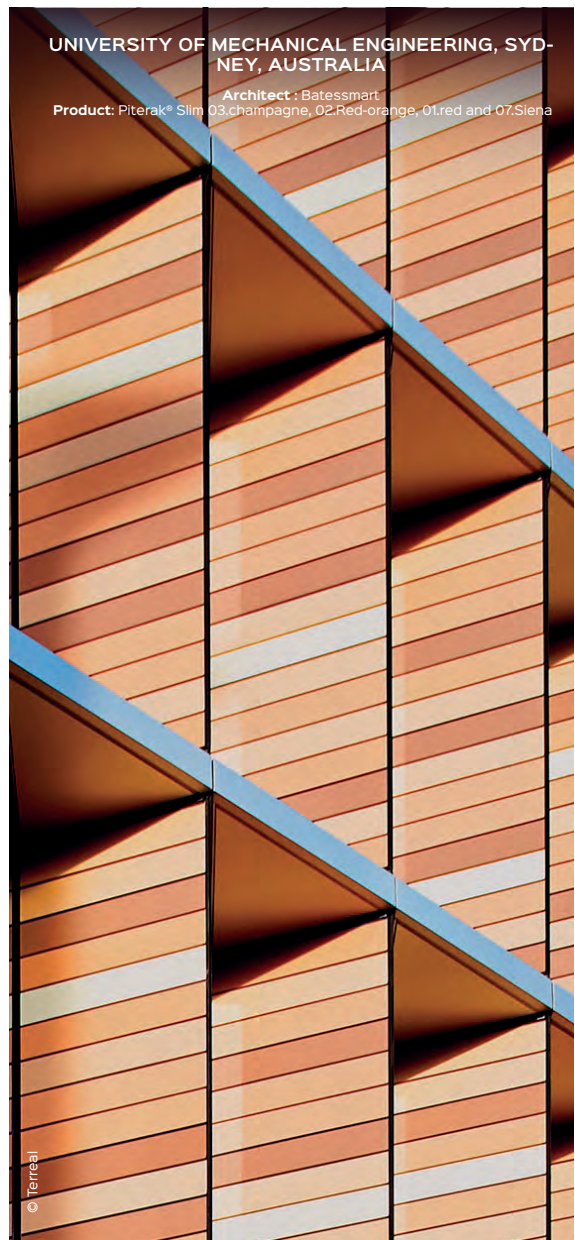

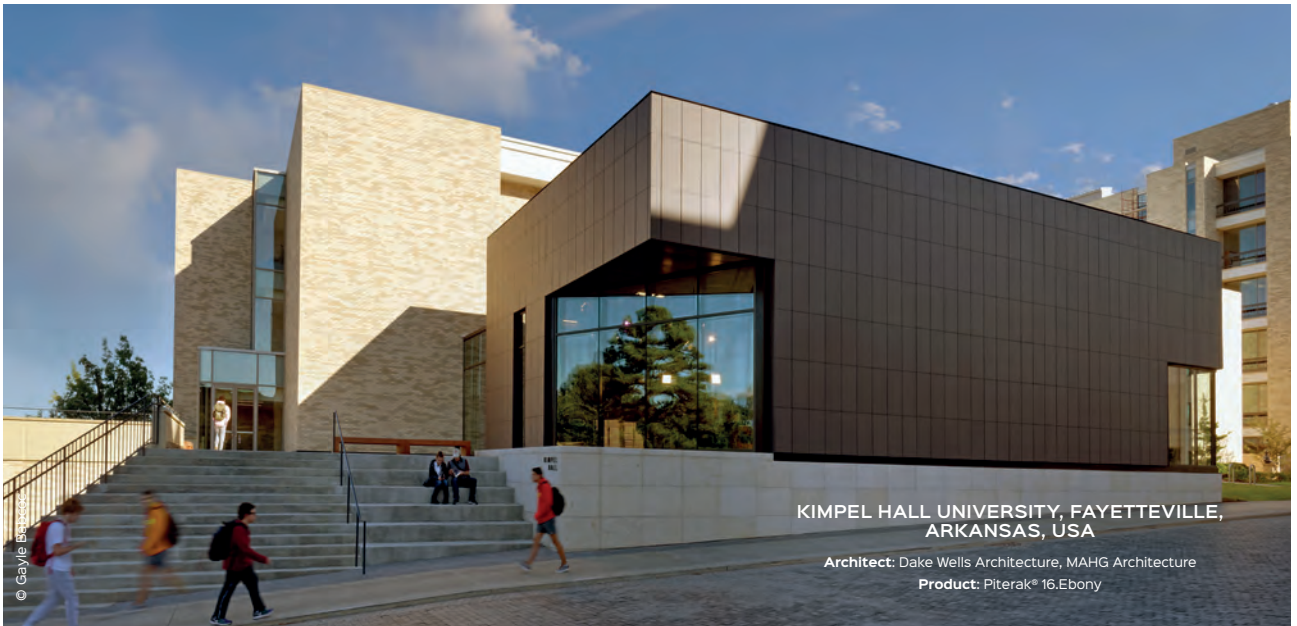

**KIMPEL HALL UNIVERSITY, FAYETTEVILLE, ARKANSAS, USA**

**Architect:** Dake Wells Architecture, MAHG Architecture  
**Product:** Piterak® 16.Ebony

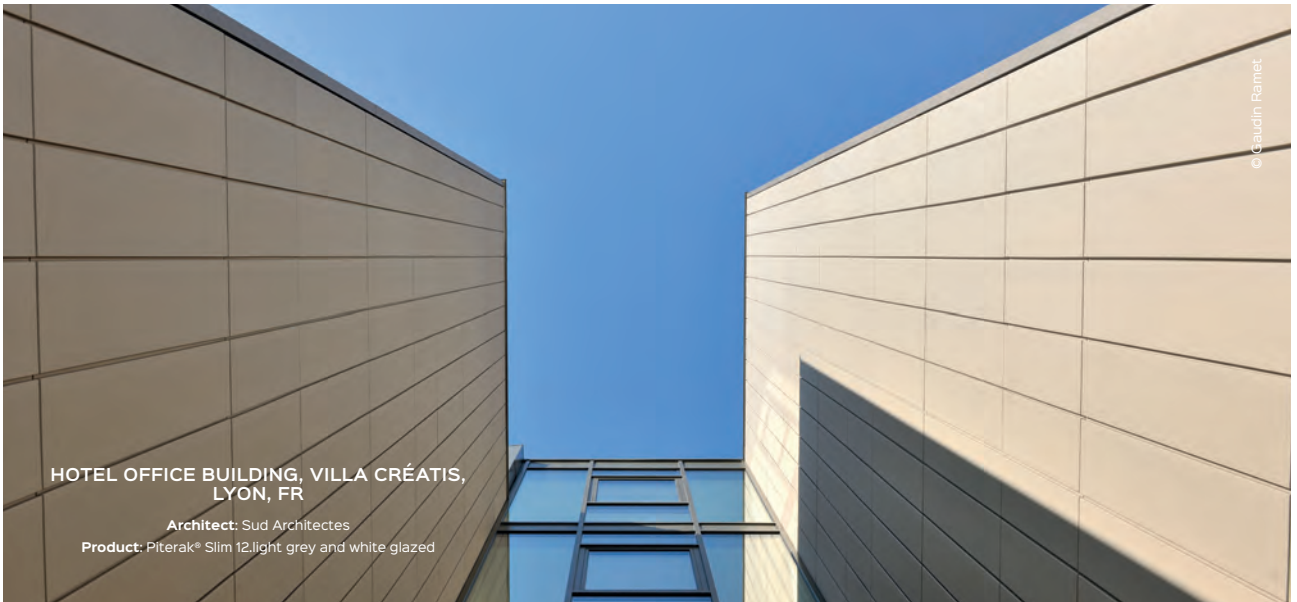

**HOTEL OFFICE BUILDING, VILLA CRÉATIS, LYON, FR**

**Architect:** Sud Architectes  
**Product:** Piterak® Slim 12.light grey and white glazed



**NORTH MANCHESTER HOSPITAL, MANCHESTER, UK**

**Architect:** Lewis & Hickey  
**Product:** Piterak® Slim and Maestral® Slim white glazed



# Piterak® XS

Cost effective, lightweight terracotta cladding



Piterak® XS is an economical 18mm thick, double-skin terracotta rainscreen cladding system with overlapping horizontal reveals. The product is a thin, lightweight, and strong medium module terracotta panel available in a variety of standard sizes and a multitude of made-to-order sizes with a maximum height of 40 cm and maximum length of 150 cm. Through reinforced structure system, the Piterak® XS system maintains a high wind and impact resistance rating. It is a terracotta cladding system that provides structural versatility and superior aesthetics in an economically superior rainscreen solution.

## STRENGTHS

- 18 mm thick
- Lightweight mineral cladding (around 30kg/m<sup>2</sup>)
- Unparalleled durability of terracotta
- Simple and fast installation using clips
- Large choice of colours
- Length up to 150 cm
- Heights from 15 to 40 cm
- **Maintenance free and durability**
- **Fire resistant**



MUSEUM OF ARTS, HISTORY  
AND SCIENCE, EVANSVILLE, USA  
Architect : VPS Architecture and Ratio Architects

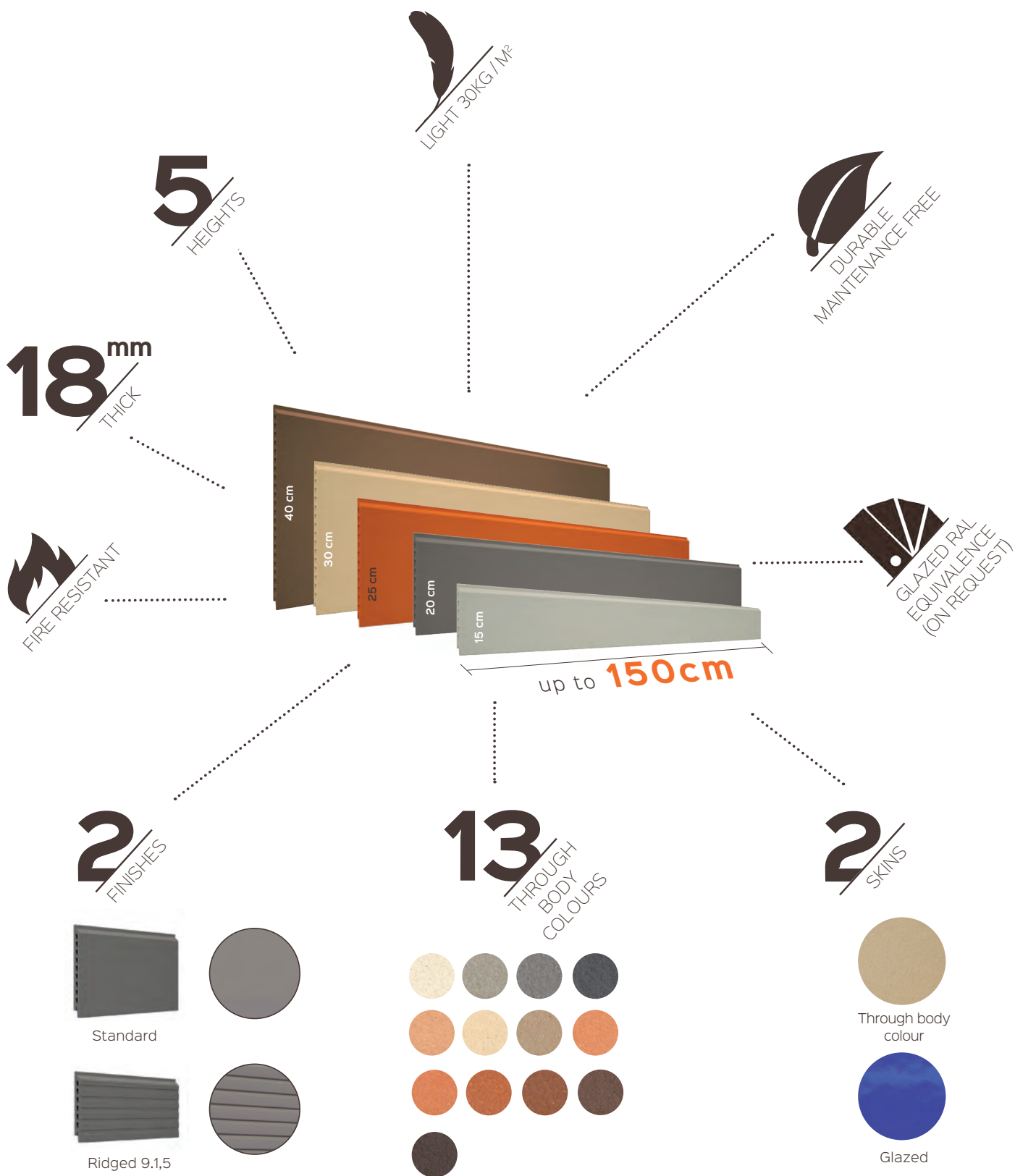

# Standard range

## STANDARD DIMENSIONS

REF. CATALOGUE	MODULE HEIGHT	MODULE LENGTH	THICKNESS	WEIGHT / M <sup>2</sup>
PX15C0	150 mm	310 to 1510 mm	18 mm	~30 kg / m <sup>2</sup>
PX20C0	200 mm			
PX25C0	250 mm			
PX30C0	300 mm			
PX40C0	400 mm			

## FINISHES

Standard



Ridged 9,1,5



Ridge dimension :  
Height 9 mm  
Depth 1,5 mm  
Ridges each 25 mm

## THROUGH BODY COLOURS



06. Sand

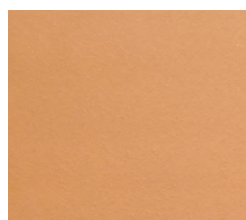

04. Salmon

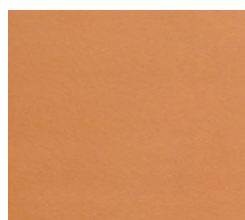

02. Red-orange

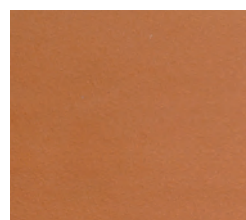

01. Red

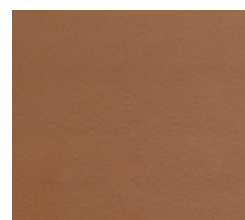

07 Sienna

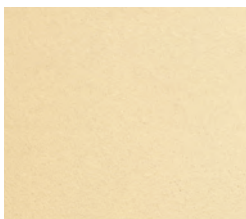

03. Champagne



11. Sahara beige

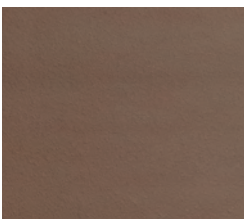

09. Coffee

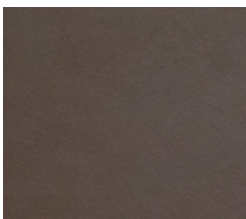

16. Ebony



12. Light grey

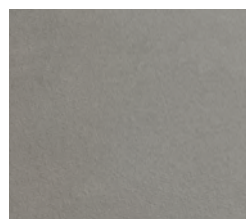

13. Storm grey

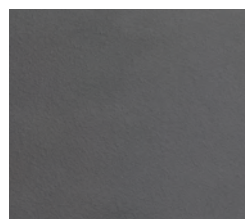

15. Slate grey

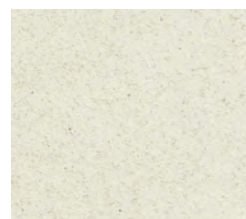

30. Arctic white  
*(Engobed colour)*

# GLAZED RANGE COLOURS



Yellow



Lichen



Orange



Red



Mars Red



Petrol blue



Cobalt blue



Egyptian violet



Calamine pink



Shadow earth



Green



Verdigris

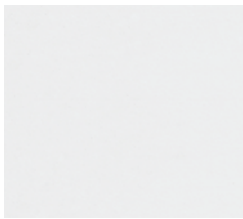

Matt white



Glossy white



Matt light grey



Glossy light grey

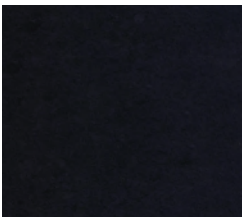

Matt black



Glossy black

## Metallic colours

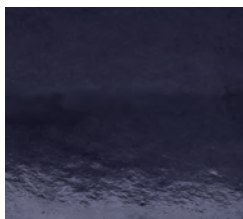

Marine black



Steel

### Custom glazed colour

TERREAL can develop on request RAL equivalent glazed colours in matt or glossy appearance.

# System characteristics

## SYSTEM DESCRIPTION

Cladding process based on 18mm thick double-wall terracotta products (~30kg / m²) with a horizontal overlap, held using special clips, to a vertical steel framework secured to the main structure, with insulation fitted behind the framework.



## CHARACTERISTICS

- Modulus of rupture > 15 MPa
- Water absorption 6 to 9%
- Frost resistance
- Fire classification A1: firing mass considered to be zero

### Fixing system

The fastening clips are made of stainless steel 1.4301 according to standard EN 10088.

The vertical support profiles are made of aluminum EN AW 6060 according to EN 755-2.

### Impact resistance:

Q3 impact resistance rating under French CSTB.

INSTALLATION	HEIGHT MODULE	MAXIMAL LENGTH	CLASSIFICATION FOLOWING FRENCH NORM 08-301/302	STEEL BALL 0,5 KG	STEEL BALL 1 KG	SOFT BALL 3 KG		SOFT BALL 50 KG	
				D0,5	D1	M3		M50	
				1 joule	3 joules	3 joules	20 joules	100 joules	130 joules
<b>Reinforced (add 1 vertical profile + clip at mid-span)</b>	20 to 40 cm	≤ 150 cm	Q3	✓		✓	✓	✓	
<b>Standard</b>	20 to 40 cm	≤ 150 cm	Q2	✓		✓	✓		
<b>Standard</b>	20 cm	≥ 150 cm	Q1	✓		✓			
<b>Reinforced (add 2 vertical profile + clip)</b>	15 cm	≤ 150 cm	Q1	✓		✓			

## PROPERTIES

### Support type:

- Concrete wall
- Coated masonry

### Certifications:

#### Product under technical assesment :

French CSTB 2.2 / 18-1793\_V1.



### Wind resistance :

The wind resistance of the Piterak® XS process is between 614 Pa and 2542 Pa (depending on format and mounting configuration).

	STANDARD INSTALLATION			REINFORCED INSTALLATION**	
	L 600 mm	L 1200 mm	L 1500 mm	L 1500 mm	
MODULE HEIGHT (MM)	150	820 Pa		1928 Pa	
	200	820 Pa		1928 Pa	
	250	2542 Pa	1840 Pa	1840 Pa	1928 Pa
	300	2542 Pa	1270 Pa ***	614 Pa	1508 Pa***
	400	614 Pa		970 Pa	

L: Length

\*\* : Installation with intermediate profile and 2 staples

\*\*\* : Values obtained following additional CSTB tests



**BIM objects available**

[www.bimobject.com/fr/terrealfacade](http://www.bimobject.com/fr/terrealfacade)

# Horizontal fixing system properties

## FIXING ACCESSORIES

Terreal provides :

- Clips for standard installation
- Vertical profiles



PITP01  
Omega profile ridged  
Piterak®  
SAP 118027



PITP06  
Omega profile Piterak®  
SAP 140961



PITP03  
Angle profile ridged  
Piterak®  
SAP 118028

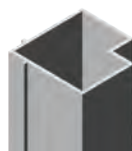

PITP04  
Angle profile  
Piterak®  
SAP 118020



PITP05  
Y profile Piterak®  
SAP 131298

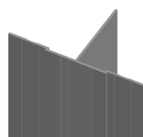

PITP07  
T profile Piterak®  
SAP 152738



PXS01  
Standard clip  
Piterak® XS  
SAP 148197



PXS01  
Bottom clip  
Piterak® XS  
SAP 130402



PXS02  
Clip for movement joints  
Piterak® XS  
SAP 148942

Estimated quantity of fixing accessories for a standard implementation and without singular points.

Values given for information.

MODULE HEIGHT X LENGTH	PITERAK® XS / M <sup>2</sup>	CLIP PXS01	PROFILE / M <sup>2</sup>
150 x 1200 mm	5,6 u / m <sup>2</sup>	11,2 u / m <sup>2</sup>	0,83 ml / m <sup>2</sup>
200 x 1200 mm	4,2 u / m <sup>2</sup>	8,4 u / m <sup>2</sup>	0,83 ml / m <sup>2</sup>
300 x 1300 mm	2,6 u / m <sup>2</sup>	5,2 u / m <sup>2</sup>	0,76 ml / m <sup>2</sup>
400 x 1500 mm	1,7 u / m <sup>2</sup>	3,4 u / m <sup>2</sup>	0,66 ml / m <sup>2</sup>

Here below the formulas to evaluate the indicative quantity per m<sup>2</sup> for an H x L frame in the running part without taking into account the singular points.

H and L are the height and length of the module and are expressed in m.

ESTIMATED CALCULATION OF QUANTITIES HEIGHT X LENGTH	
Piterak® XS / m <sup>2</sup> quantity	1 / (H x L)
Clip / m <sup>2</sup> quantity	2 / (H x L)
Clip / m <sup>2</sup> quantity	1 / L
Profile / m <sup>2</sup> , quantity (ml)	1 / (3 x L)



For the final order, a precise layout must be carried out by the installation company in order to take into account all the singular points of the site.

Other supplies necessary for the implementation are not offered by Terreal (insulation, fixing screws, dowels or lag bolts, brackets, profile bay trim, lower part starting grid, profile angle, ...). They are the responsibility of the installation company.



ZOOM ON ...  
Installation  
guide video

[www.youtube.com/user/terrealvideos](http://www.youtube.com/user/terrealvideos)



## PRIOR RECOMMENDATIONS

The implementation of vertical profiles must respect the rules of the technical assesment : French CSTB 2.2 / 18-1793\_V1.

The layout is carried out beforehand by the company installation, to determine the positioning of vertical profiles as well as the dimensions of Piterak® XS.

To define the vertical layout correctly it is necessary to consider a vertical space between 2 products of 10 mm (this space can be increased to 20 mm maximum).

## IMPLEMENTATION

The vertical profiles are fixed to the walls by square brackets (or stirrups) fixed to the profiles by stainless steel drilling screws. So fixed this frame is called "bridle".

The profiles must be fixed so as to adjust the verticality and horizontality of the profiles between them.

The number and arrangement of the brackets (or stirrups) is determined by calculation, depending on the area of intended use, by the supplier of the brackets.

The implementation of Piterak® XS is done from the bottom to the top, once the frame is aligned vertically and horizontally and that the insulation is put in place (when necessary).

First, the bottom clips are fixed in the lower part (PXS01), aligning with the horizontality.

The clips are fixed to the vertical profiles with stainless steel screws.

The Piterak® XS is placed on the bottom clip then the standard clips (PXS01) are positioned in the upper part of the Piterak® XS and at its ends.

A space between the clip and the top of the terracotta should be spared.

To facilitate the installation / fixing of the clips, a tracing can be carried out on profiles at each module height (example for Piterak® XS 30 : height of 30 cm module = marking on profile every 30 cm).

Thus assembled, the horizontal joint between 2 products will be about 7 to 11 mm.



**\*\* Check with local industry standards and local guidlines as requirements varies from Country to Country.**

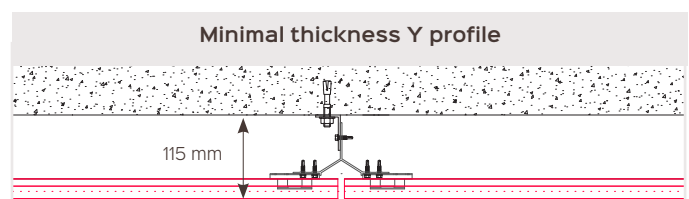
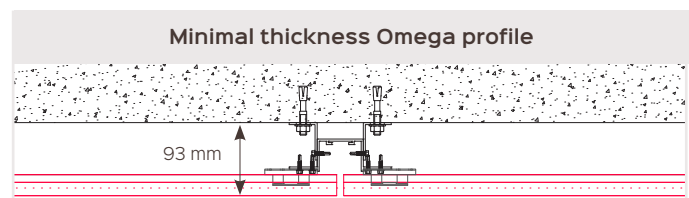
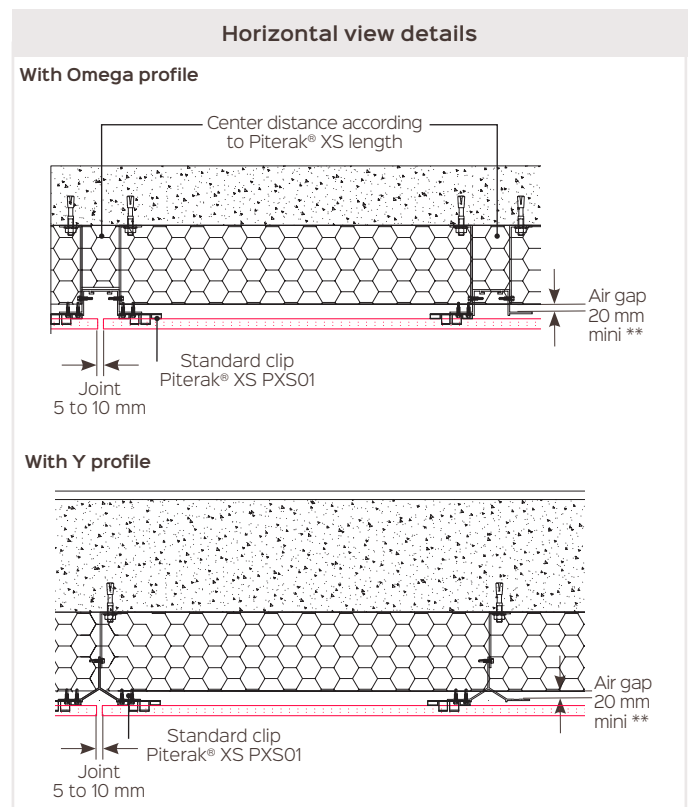
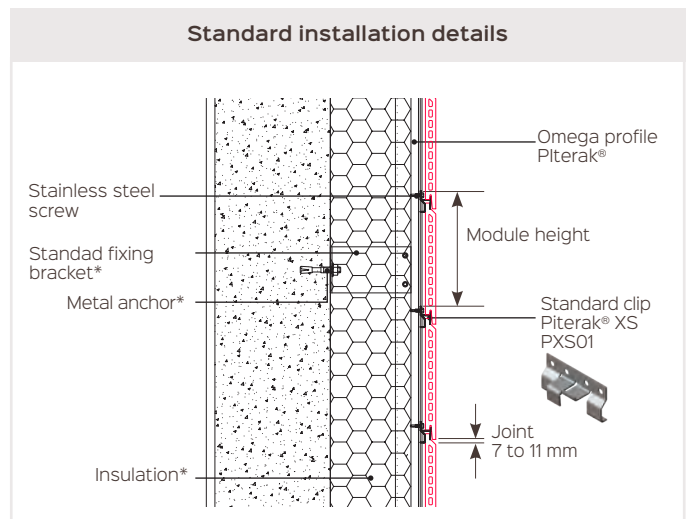

\*Not provided by Terreal

# Horizontal fitting guide



Bottom detail

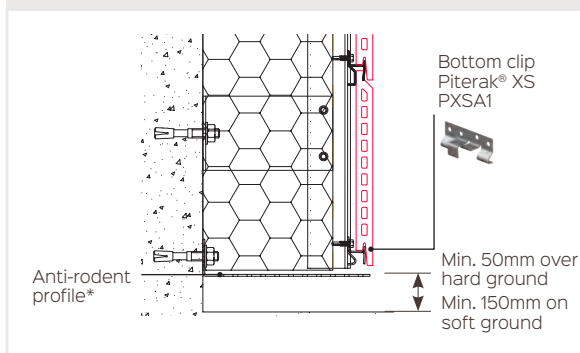

Top detail

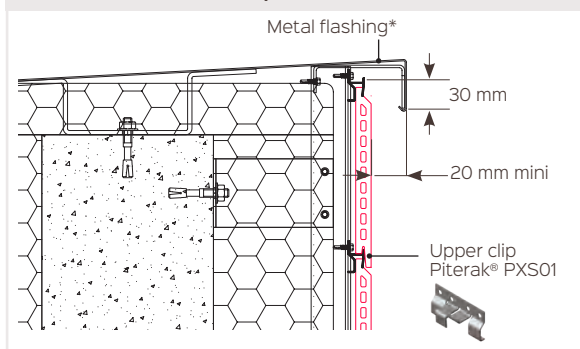

## SINGULAR POINTS

### Bottom details

In the lower part, it is necessary to respect a minimum height between the ground and the bottom of the starting Piterak® XS element.

- Height is 50 mm on hard ground or 150 mm on soft ground for application on concrete wall or traditional coated masonry.

### Top details

A metal capping must be placed in the upper part or parapet to limit the penetration of rainwater.

- The metal capping must have a fall in front of the terracotta of 30 mm and must overhang the Piterak® XS by at least 20 mm.
- Thus dimensioned, this capping prevents rainwater from flowing directly onto the Piterak® XS and allows good ventilation of the air gap. A regular flow of water promotes the appearance of foam on the products : this degrades the aesthetics of the facade and results in a need of regular cleaning operation.

## SINGULAR POINTS

### Window sill

The sill is treated using a metal flashing which must have a fallout in front of the terracotta of 30 mm and must protrude 20 mm from the Piterak® XS.

### Lintel

The lintel is treated with a metal flashing. The Piterak® XS is used in the same way than for the starting part.

A space of 10 mm is required between the flashing and the bottom of the Piterak® XS above the lintel.

- 15 / 10th thick metal flap installed with a slight inclination to reject humidity to the outside.
- Ideally, this flap is perforated to ensure good ventilation of the air space.

### Jamb

In jambs, returns are treated with metal profiles (angles, ..) A space of 10 to 20 mm is required between the profile and the ends of the Piterak® XS.

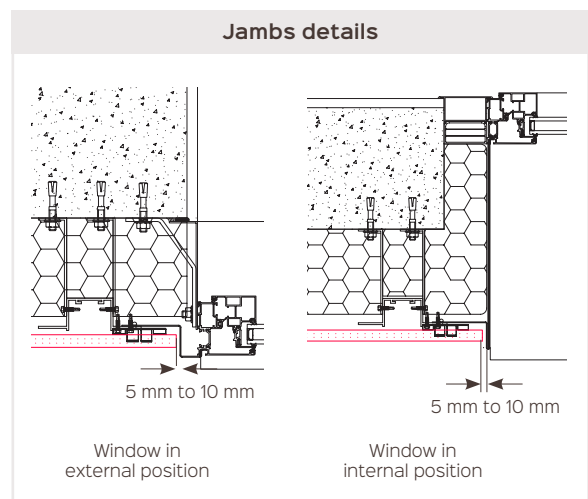
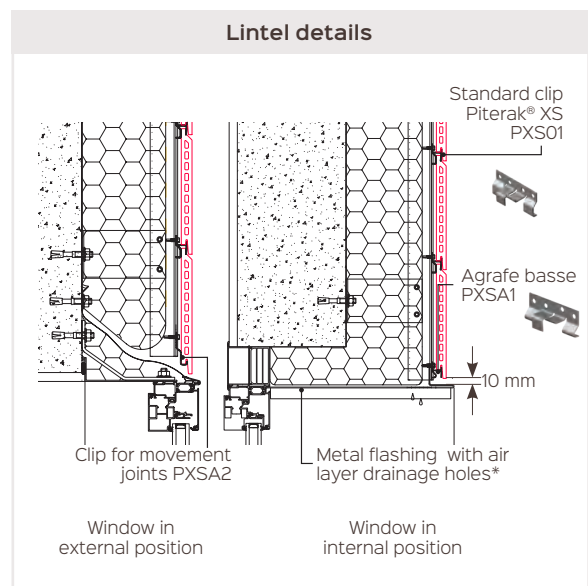
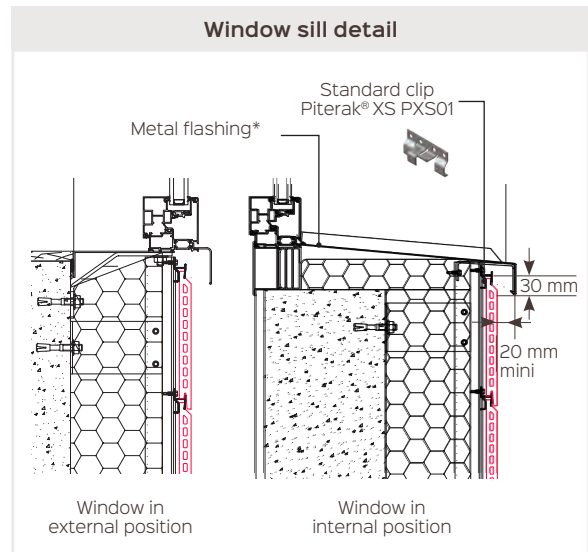

\*Not provided by Terreal

# Horizontal fitting guide

## External angle with profile

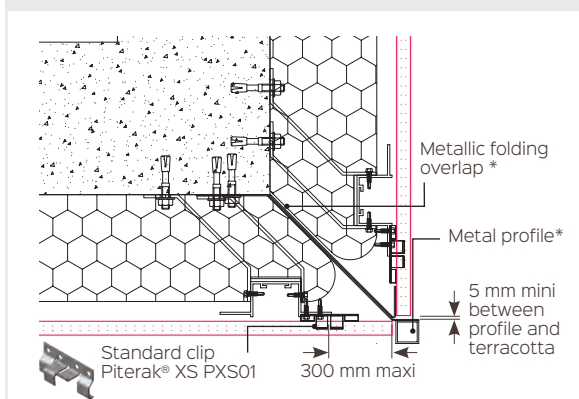

## External angle with miter cut product

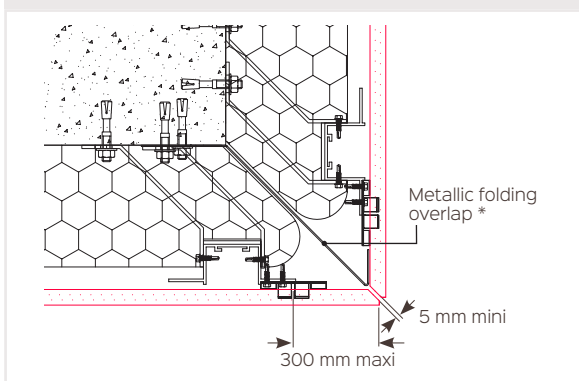

## Internal angle detail

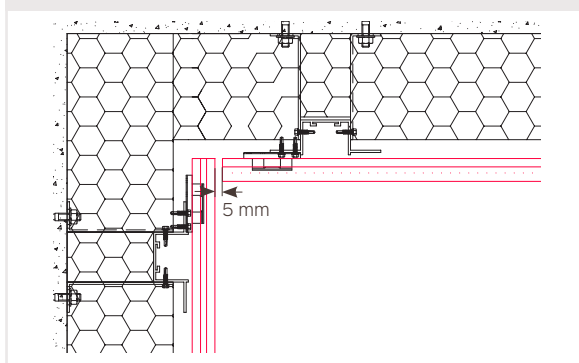

## SINGULAR POINTS

### External angle

#### With profile :

A metal profile (generally lacquered, not sold by Terreal) handles the angle. This profile can be either recessed or flush with the outside nude facades. In all cases a space of 5 mm is required between the profile and the ends of Piterak® XS.

#### Without profile :

Piterak® XS are cut at one end on the edge of the product. The cutting angle is 45 ° and a 5 mm dish is kept (miter cut).

### Internal angle

Internal angles are treated with standard products. A space of 2 to 5 mm is required between Piterak® XS.



## SINGULAR POINTS

### Frame splitting

The vertical profiles being mounted in a clamped manner (no sliding points) it is necessary to have a space between each profile. This allows to absorb aluminum expansions induced by thermal variations.

This can be done using a flashing metal or no.

Without flashing metal :

Frame splitting can be done without flashing metal. In this case, a space should be left between 2 profiles at least 8 mm.

In no case should the Piterak® XS be bridged on 2 consecutive vertical profiles.



Never bridge a product on 2 consecutive profiles.

### Expansion joint

The space to be kept between 2 adjacent Piterak® XS, is at least the thickness of the expansion joint with a minimum of 20mm.

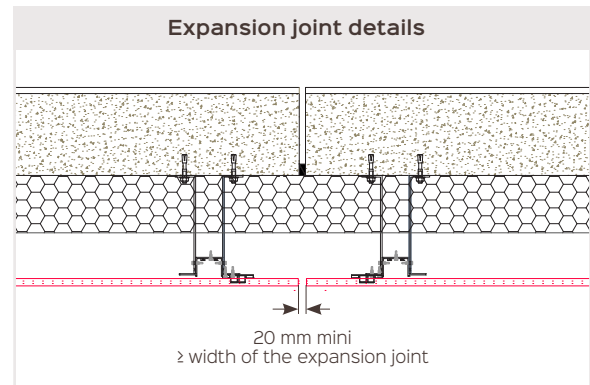
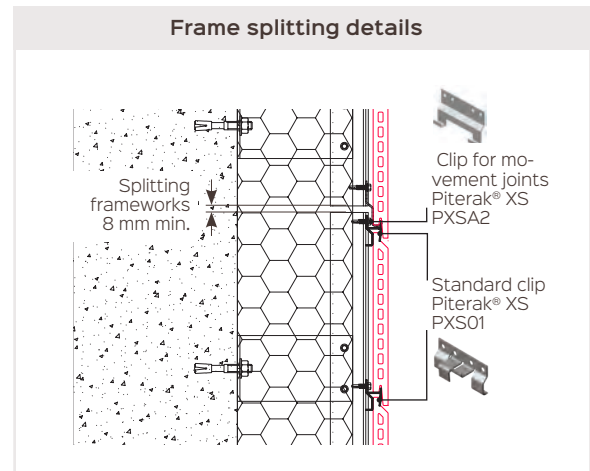

# Wood frame wall fitting guide

## SYSTEM DESCRIPTION

Cladding process based on 18 mm thick double-wall terracotta products (~30 kg / m<sup>2</sup>), Piterak® XS can be installed on wooden framework on a composite framework with profiles with center distance of 645 mm maximum located to the right of the timber frame wall uprights and respecting the following recommendations:

- Reserve a minimum 20 mm air space between the wall and siding. Check with local industry standards as minimum air gap above 20mm varies from Country to Country.
- Length of vertical aluminum profiles limited to 3m.
- The layout must take into account the center distance of the uprights of the timber frame wall.
- The vertical profiles must be fixed to the right of rafters.
- The support wall must comply with NF DTU 31.2.



Installation on wooden frame wall in accordance with NF DTU 31.2, is limited to:  
**Maximum height of 10 m** (+ point gable) in wind zones 1, 2 and 3 in ,situations a, b and c, maximum height 10 m (+ pinion point) in situation d.

**Check with local industry standards and local guidelines as requirements varies from Country to Country.**

## PROPERTIES

### Support type :

- Wood frame wall (according to NF DTU 31.2) up to 10 m (see 2.2 / 18-1793\_V1).

### Certifications

Technical advice for horizontal installation n° 2.2/18-1793\_V1.



### Impact resistance :

Q3 impact resistance rating under French CSTB.

Ridged finish : Q2 with 2 intermediate profiles.

### Wind resistance :

MODULE HEIGHT (MM)	STANDARD INSTALLATION			REINFORCED INSTALLATION**
	L 600 mm	L 1200 mm	L 1500 mm	L 1500 mm
150		820 Pa		1928 Pa
200		820 Pa		1928 Pa
250	2542 Pa	1840 Pa	1840 Pa	1928 Pa
300	2542 Pa	1270 Pa***	614 Pa	1508 Pa***
400		614 Pa		970 Pa

L: Length

\*\* : Installation with intermediate profile and 2 staples

\*\*\* : Values obtained following additional CSTB tests

\*Not provided by Terreal

## INSTALLATION

A rain barrier conforming to NF DTU 31.2 must be placed on the outside of the wall of the timber frame wall.

With the joints open, the rain screen will have a UV resistance of 5000 h according to standard NF EN 13589-2. In situations a, b and c, the bracing panels of the timber frame wall can be positioned on the inside or outside of the wall. In situation d, if the bracing panels of the wooden frame wall have been positioned on the inside of the wall, wood-based panels must be positioned on the outside of the wall.

The rain screen is cut every 6 m to evacuate surface runoff water. Under no circumstances should the rain screen be placed against the cladding product (air gap of 20 mm minimum).

The profiles are attached to the uprights of the timber frame wall using wood screws of minimum dimension  $\varnothing 7 \times 50$  mm.

The characteristic PK pullout resistance is 598 daN for an anchoring of 50 mm in a wooden support.

Each clip is fixed to the right of the omega profiles using 2 self-drilling screws 5.5 x 22 mm. Only the omega profiles are compatible with installation on a wooden frame wall. The frame is split on each floor. Bridging of junctions between successive uprights by shingles is excluded.

The figures illustrate the minimum installation arrangements on the timber frame wall. Situations a, b, c and d are defined in NF DTU 20.1.

### Corners

Piterak® XS are cut at one end on the edge of the product. The cutting angle is 45° and a 5 mm dish is kept (miter cut)

**!** Check with local industry standards and local guidelines as requirements varies from Country to Country.

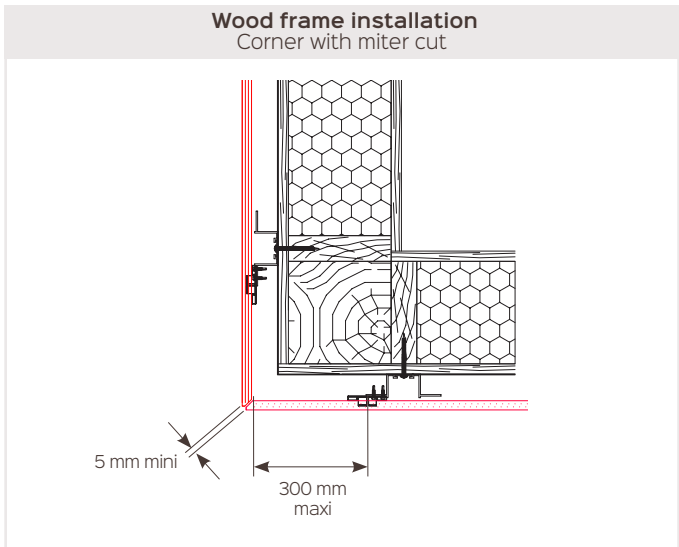
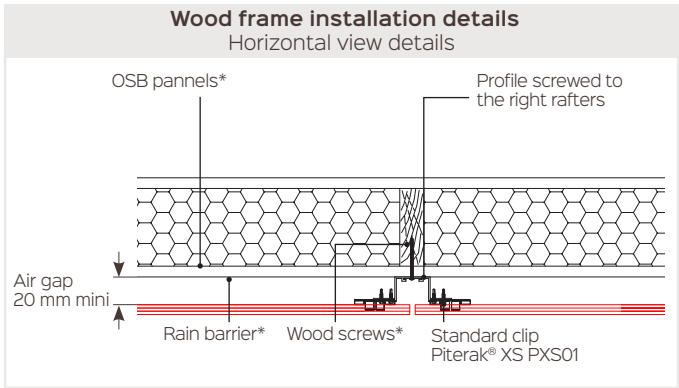
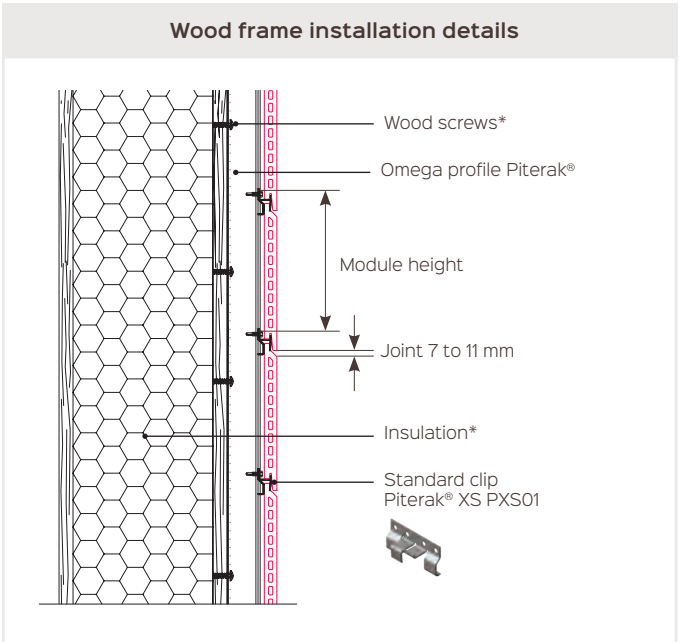

\*Not provided by Terreal

# Wood frame wall fitting guide

## Wood frame installation Window bottom details

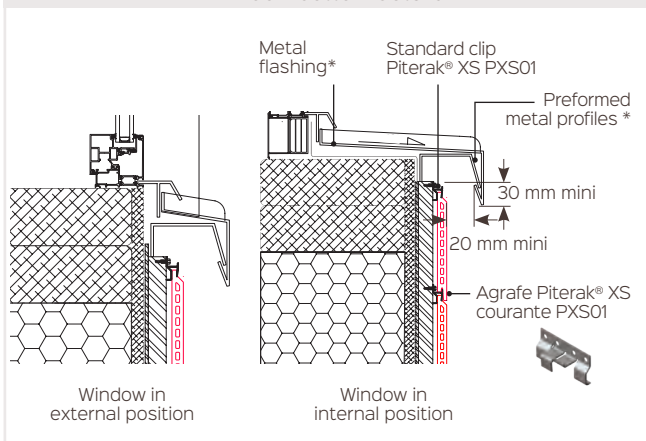

## SINGULAR POINTS

### Window bottom details

The sill is treated using a metal flashing which must have a fallout in front of the terracotta of 30 mm and must protrude 20 mm from the Piterak® XS.

### Lintel details

The lintel is treated with a metal flashing. The Piterak® Slim is used in the same way than for the starting part.

A space of 10 mm is required between the flashing and the bottom of the Piterak® XS above the lintel.

### Jambs details

In jambs, returns are treated with metal profiles (angles, ..) A space of 10 to 20 mm is required between the profile and the ends of the Piterak® XS.

## Wood frame installation Lintel details

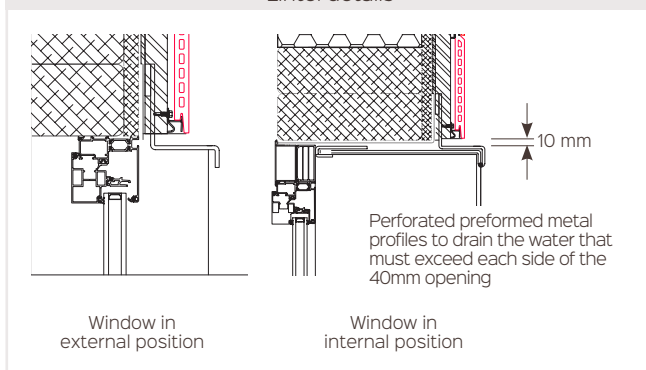

**Check with local industry standards and local guidelines as requirements varies from Country to Country.**

## Wood frame installation Jambs details

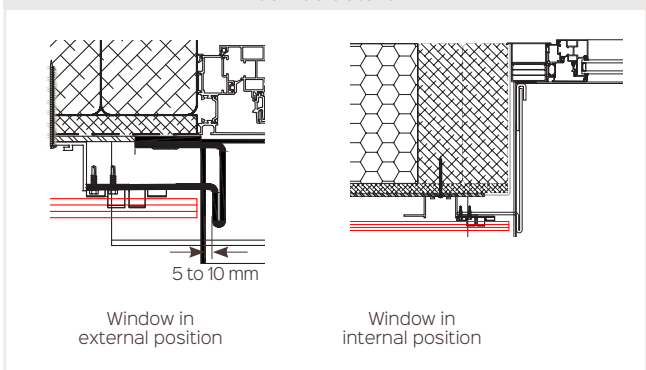



# Seismic zone installation

Piterak® XS 20 to 40 x 150 cm can be used in seismic zones :

- Omega profile linked each other
- Bracket Isolo C2 depthness 50 to 240 mm

SEISMIC TEST	FREQUENCY (HZ)	NUMBER OF CYCLE	AMPLITUDE (MM)	ACCELERATION (M/S <sup>2</sup> )	PASSED
Parallelogramm test	0,2 ≤ f ≤ 1 Hz	20	± 60 mm	-	✓
Test in the plane of the support	3	10	± 46,4 mm	16,5	✓
	5,99 Damped natural frequency	5	± 11,6 mm	16,5	✓
Test perpendicular to the plane of the support	15	10	± 1,9 mm	16,5	✓
	3	20	± 26,2 mm	9,3	✓
	15	20	± 1,6 mm	9,3	✓

## CONCRETE WALL

### Profiles

Installation in seismic zone only with Omega profile and brackets (ISOLCO up to 240 mm)

Omega profiles are joined to each other by an aluminum profile fixed on the back of the omega profiles.

The vertical center distance of the L profile is 100 cm maximum.

### Isolco brackets up to 240 mm maximum

The brackets are doubled (in opposition). The spacing vertical between the brackets is 100 cm maximum.

### Load-bearing structures

The load-bearing structures are split every levels. Piterak® XS must not be bridged between 2 levels.

### Anchoring the brackets

On concrete wall (NF DTU 23.1), the anchoring of the brackets is made using A4 plugs type FM 753 CRACK Ø 12

## WOOD FRAME WALL

### Profiles

Installation in a seismic zone on a wooden frame wall with direct installation of the profiles on the rafters of the wood frame wall.

The omega profiles are directly fixed to the right of the rafters with lag bolts type TH 13 ZN.

### Load-bearing structures

The load-bearing structures are divided at all levels. Piterak® XS must not be bridged between 2 levels.

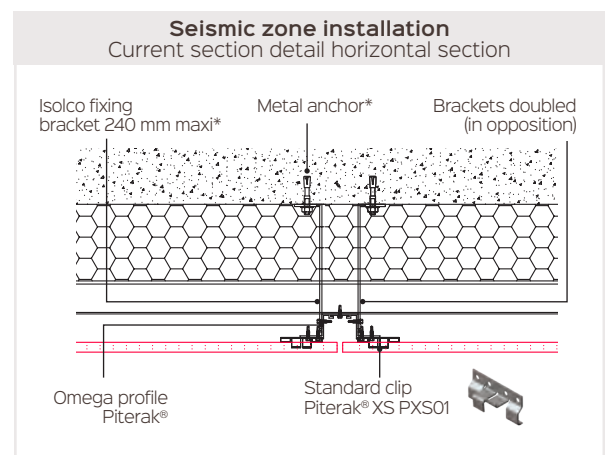
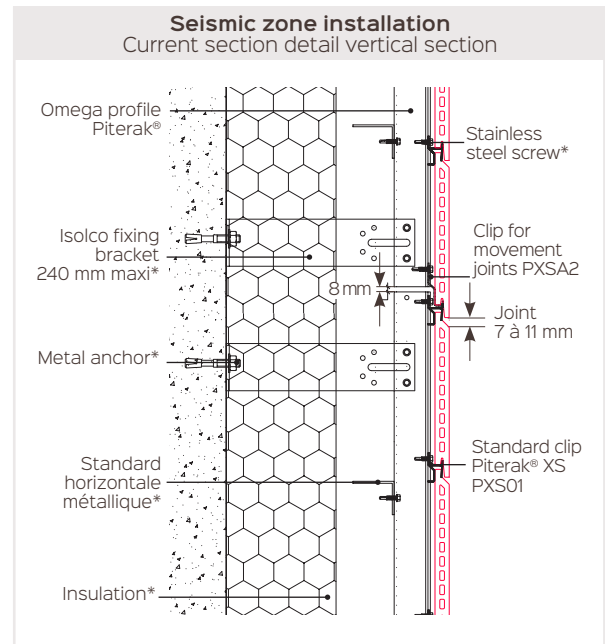

Concrete wall installation :

- Installation in seismic zone with omega profile only
- Bracket up to 240 mm max.
- Max vertical center distance, L profiles: 100cm
- Double brackets (in opposition)
- Load-bearing frame split at each level

Wood frame wall installation :

- Installation in seismic zone with omega profile only
- Load-bearing frame split at each level

\*Not provided by Terreal



# Seismic zone installation

## SINGULAR POINTS

### Corners

At each corner exiting the 40/10<sup>th</sup> steel side stops must be positioned.

Installation of mitered angles in seismic installation is not referred to in the technical opinion.

### Expansion joint

In front of the expansion joints, bridging of the joint with terracotta is excluded and a folded profile device must be implemented so that it protects the insulation while absorbing the differential movements due to the expansion joints.

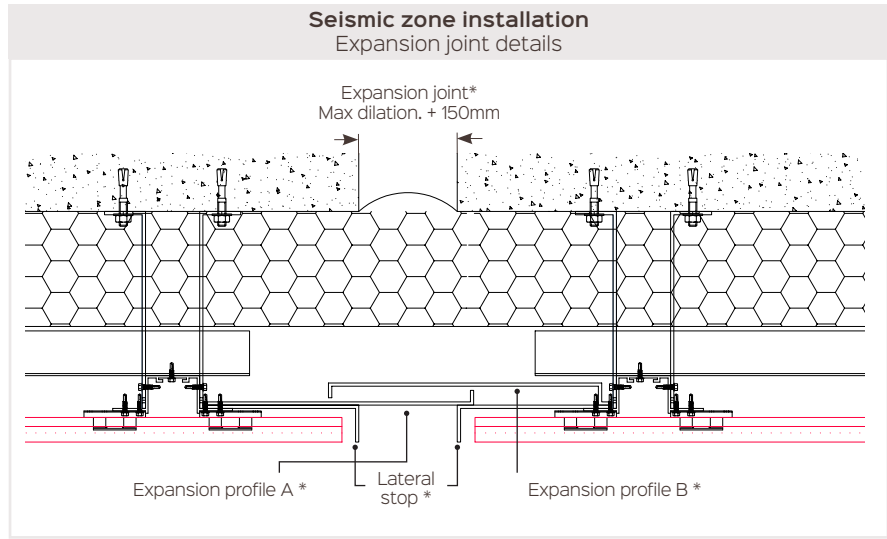
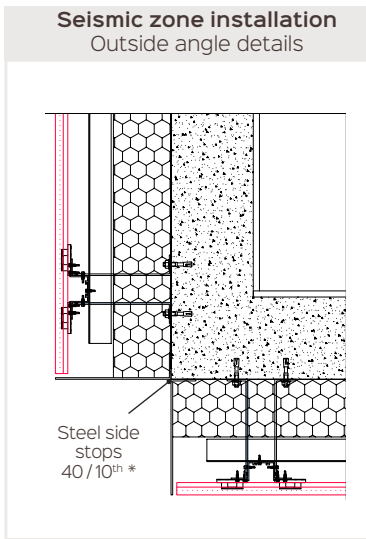

### Lateral stop

A lateral stop must be implemented every 4 frames (4x180 cm or 7.3 m maximum) using metal profiles fixed to the vertical profiles.

Example: 4 x 180 cm or 7.2 m maximum.

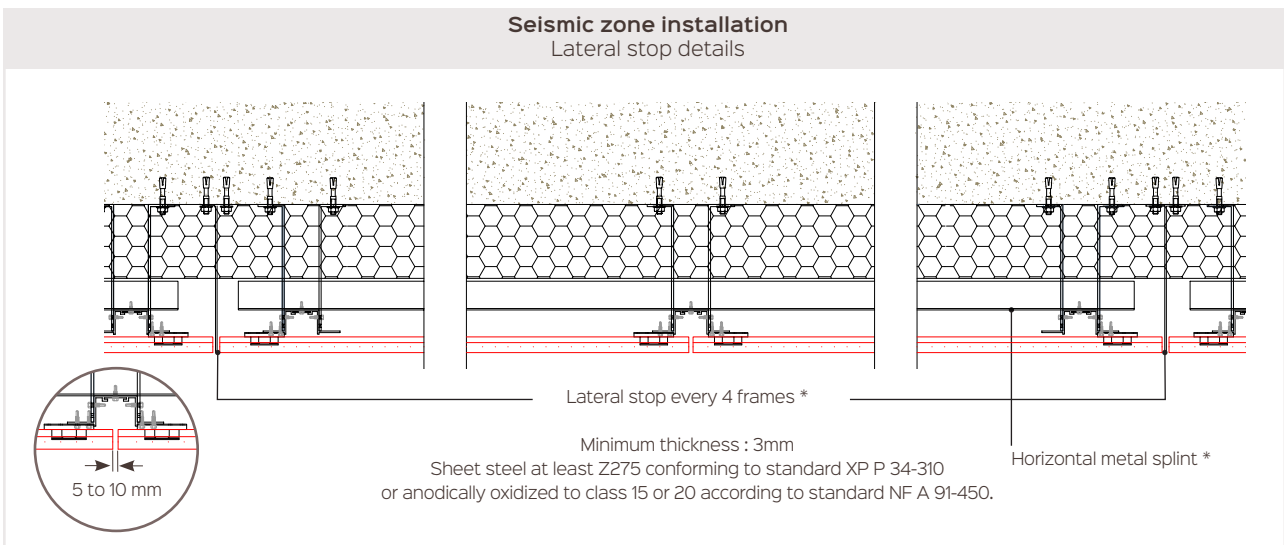

\*Not provided by Terreal

# Replacement Guide



Broken product.



Remove the broken product.



Locate the positioning of the 2 visible standard clips.



Trace the cutting area on the replacement product. The cutting of the product in the upper part is necessary in order to be able to fit the cut area in the upper clip

Cut out each side of the Piterak® XS.



Put dots of glue on the clips (use polyurethane glue type SIKAFLEX 11 FC).



Put the replacement product in place by first inserting the upper part, pushing towards the wall then exerting downward pressure to position it at the bottom of the clips.

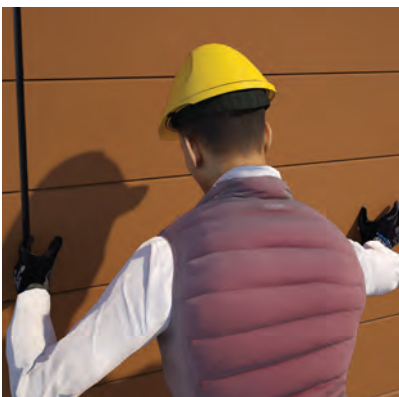

Position the product on the clips.

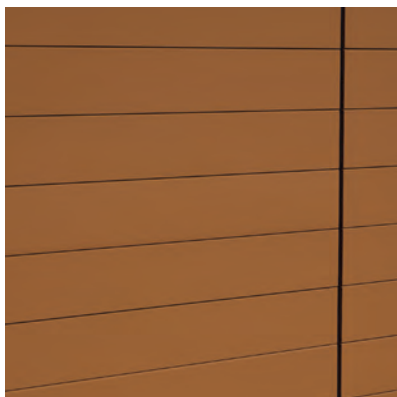

The product is replaced.



© Terreal

**EVANSVILLE MUSEUM OF ARTS, HISTORY  
& SCIENCE, EVANSVILL, USA**

**Architect:** VPS Architecture and Ratio Architects  
**Product:** Piterak® XS white glazed

KENT STATE UNIVERSITY - STARK FINE ARTS CAMPUS BUILDING,  
KENT, USA

Product: Piterak® Slim standard, custom and ridged 07.Siena and 03.Champagne  
Architect:



© Gaj/e Harcock

PROMEDICA HEADQUARTERS,  
TOLEDO, OHIO, USA

Product: Piterak® XS 13.Storm grey and 15.Slate grey  
Architect: HKS Inc.



© Terreal

DUKE UNIVERSITY, STUDENT WELLNESS CENTER,  
DURHAM, NORTH CAROLINA, USA

Product: Piterak® XS 12.light grey and 13.storm grey  
Architect: Duda Paine Architects



© Robert Benson Photography



© Terreal

GIRLS INC. - KATHERINE FLETCHER CENTER,  
OMAHA, USA

Architect: The Architectural Offices in Omaha  
Product: Piterak® XS white, grey, red, blue glazed

RAINSCREEN CLADDING RANGE

SUNSCREEN

WALL BRICKS



# Sunscreen range

To answer the many requirements of building envelopes and specifically the expectations regarding sun protection, TERREAL offers a wide range of terracotta baguettes that can be used to build sunscreens, wall claddings or visual screens.

As an integral part of the façade, sunscreens provide thermal comfort, let natural light in, and help reduce blinding effects without blocking visual contact with outside. They truly bring façades to life and allow the designers to play with shadows, while combining thermal comfort, control of sunlight input and optimization of natural daylight.

# Sunscreen range

Architectural terracotta baguettes



TERREAL offers a range of sunscreen rich in formats and lengths. It revolves around 4 shapes products: the Autan® line in square shape, the Zonda® in rectangular shape, the Harmattan® in ovoid shape, the Shamal® in the shape of an airplane wing.

Terracotta sunshades enhance the aesthetics of facades and go perfectly with the other products in the Terreal range. Multifunctional, they are used in cladding, sunscreen, pergolas, screening, ventilation grilles, etc.

**Pre-assembled at factory option available**

## STRENGTHS

- Effective solar protection
- Optimization of summer comfort
- Wide choice of shapes and colours
- No glare phenomenon
- No wind noise
- Unrivalled durability of terracotta
- Simple and fast installation thanks to the Terreal system
- Pre-assembled at factory option available



MUSEU A CASA, SAO PAULO, BRÉSIL

Architect : Rocco Vidal Perkins + Will



# LONG LENTH SUNSCREEN

2 / SKINS

13 / THROUGH BODY COLOURS

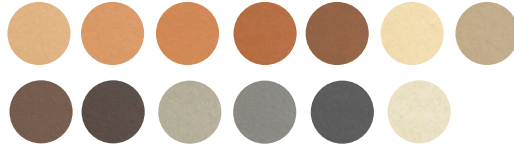

# SHORT LENTH SUNSCREEN

3 / SKINS

9 / THROUGH BODY COLOURS

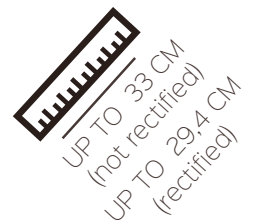

# Standard range

## STANDARD DIMENSIONS

PRODUCT	REF. CATALOGUE	SECTION DIMENSION	LENGHT	NUMBER OF CAVITY	CAVITY SECTION	WEIGHT/ML
AUTAN® XL	AX05CO	50 x 50 mm	300 to 1500 mm	1	30 x 30 mm	3,3 kg / ml
HARMATTAN® XL	HA10ET	100 x 50 mm	300 to 1500 mm	1	30 x 30 mm	6,2 kg / ml
ZONDA® XL 10	ZX10ET	100 x 50 mm	300 to 1500 mm	1	30 x 30 mm	6,5 kg / ml
ZONDA® XL 15	ZX15ET	150 x 50 mm	300 to 1500 mm	2	30 x 30 mm	9,8 kg / ml
SHAMAL® XL 15	SH15CO	150 x 51 mm	300 to 1500 mm	1	30 x 30 mm	7,2 kg / ml
SHAMAL® XL 20	SH20CO	200 x 51 mm	300 to 1500 mm	2	30 x 30 mm	10,5 kg / ml
AUTAN®	AU05NR / RE	50 x 50 mm	330 mm not rectified / 294 mm rectified	1	30 x 30 mm	3,3 kg / ml
HARMATTAN®	HA10NR / RE	100 x 50 mm	330 mm not rectified / 294 mm rectified	1	30 x 30 mm	6,2 kg / ml



### THROUGH BODY COLOURS RANGE

Autan® XL, Zonda® XL, Shamal® XL & Harmattan® XL



### THROUGH BODY COLOURS RANGE Autan® & Harmattan®





## GLAZED RANGE COLOURS



Yellow



Lichen



Orange



Red



Mars red



Petrol blue



Cobalt blue



Egyptian violet



Calamine pink



Shadow earth



Green



Verdigris

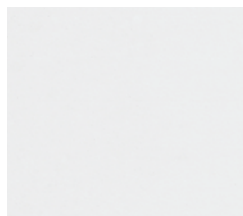

Matt white



Glossy white

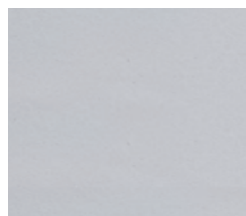

Matt light grey



Glossy light grey

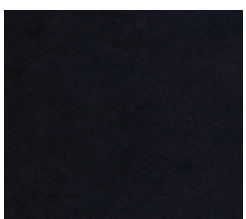

Matt black



Glossy black



Colours not available in Autan® and Harmattan®

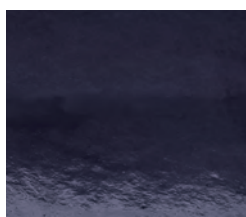

Marine black



Steel

### Custom glazed colour

Terreal can develop on request RAL equivalent glazed colours in matt or glossy appearance.

# System properties

## FIXING SYSTEM

TERREAL sunscreen system is easily assembled on site and quickly installed on an aluminium framework. Available in four standard sizes, the installation kit can be adapted to all desired lengths by simply cutting the aluminium tube, and can reach up to 180cm. Its modular design allows varying the center spacing between sunscreen rows as well as their orientation. It can be installed either vertically or horizontally and offers total architectural freedom.

The system is installed between profiles for Shamal® XL range and in front of profiles for Autan® XL, Zonda® XL, Autan®, Harmattan® and Harmattan® XL ranges.

SYSTEM	Aluminum and stainless steel
PREASSEMBLED VERSION	Available in factory assembled version
STANDARDS MODULES DIMENSIONS	1000, 1200, 1500 and 1800 mm
INSTALLATION	Anodized or raw
CENTER BETWEEN VERTICAL PROFILES	up to 1800 mm
FLOOR TO FLOOR SUB-FRAME	3 m profile available
EMBEDDED INSTALLATION	For Shamal® XL ranges
CANTILEVER INSTALLATION	For Autan® XL, Zonda® XL, Autan®, Harmattan® and Harmattan® XL



**BIM objects available**  
[www.bimobject.com/fr/terrealfacade](http://www.bimobject.com/fr/terrealfacade)

## KIT DELIVERING

### Kits delivered separately

As standard order, the kits are packaged separately from the terracotta as they will be delivered on the same trucks at the same time.



Kits delivered separately

### Pre-assembled kits at the factory

In order to optimize the installation time, Terreal proposes a service to assembly the kits on the terracotta products at the factory. Thus, the installation on site is simplified and consist to fix pre-assembled kits to vertical profiles, previously fixed to the support wall.



## PROPERTIES

### Wind resistance

Permissible wind pressure

SUNSCREEN PRODUCT	KIT 1000 & 1200 MM	KIT 1500 & 1800 MM
Autan® Harmattan® Autan® XL Zonda® XL 10 & 15 Shamal® XL 15 & 20	2868 Pa	2285 Pa

### Seismic resistance

Autan® XL : kit up to 180 cm  
 Bracket Isolo C2 depthness 100 to 200 mm

SEISMIC TEST	FREQUENCY (HZ)	NUMBER OF CYCLE	AMPLITUDE (MM)	ACCELERATION (M/S²)	PASSED
Parallelogram test	0,2 ≤ f ≤ 1 Hz	20	± 60 mm	-	✓
Test in the plane of the support	3	10	± 46,4 mm	16,5	✓
	6,9 Damped natural frequency	5	± 8,8 mm	16,5	✓
	15	10	± 1,9 mm	16,5	✓
Test perpendicular to the plane of the support	3	20	± 31,5 mm	9,3	✓
	15	20	± 1,6 mm	9,3	✓

Zonda® XL 15 : kit up to 180 cm  
 Bracket Isolo C2 depthness 100 to 200 mm

SEISMIC TEST	FREQUENCY (HZ)	NUMBER OF CYCLE	AMPLITUDE (MM)	ACCELERATION (M/S²)	PASSED
Parallelogram test	0,2 ≤ f ≤ 1 Hz	20	± 60 mm	-	✓
Test in the plane of the support	3	10	± 39,4 mm	14	✓
	4,36 Damped natural frequency	5	± 18,7 mm	14	✓
	15	10	± 1,6 mm	14	✓
Test perpendicular to the plane of the support	3	20	± 31,5 mm	9,3	✓
	14	20	± 1,6 mm	9,3	✓

## Impacts resistance

According to NF P 08 301/302

INSTALLATION	PRODUCT	TERRACOTTA UNITS BY KIT	LENGHT KIT	CLASSIFICATION FOLOWING FRENCH NORM 08-301/302	HARD STEEL BALL 0,5 KG	HARD STEEL BALL 1 KG	SOFT BALL 3 KG		SOFT BALL 50 KG		
					D0,5	D1	M3		M50		
					1 JOULE	3 JOULES	3 JOULES	20 JOULES	100 JOULES	130 JOULES	
Standard	Autan®	4	≤ 120 cm	Q1	✓			✓			
		5	≤ 150 cm								
		6	≤ 180 cm								
	Harmattan®	4	≤ 120 cm	Q1	✓			✓	✓		
		5	≤ 150 cm								
		6	≤ 180 cm								
	Autan® XL	2	≤ 120 cm	Q2	✓			✓	✓		
		2	≤ 150 cm								
		2	≤ 180 cm								
	Autan® XL	1	≤ 120 cm	Q1	✓			✓	✓		
	Harmattan® XL	2	≤ 120 cm	Q2	✓			✓	✓		
		2	≤ 150 cm								
		2	≤ 180 cm								
	Harmattan® XL	1	≤ 120 cm	Q1	✓			✓	✓		
	Zonda® XL 10	2	≤ 120 cm	Q2	✓			✓	✓		
		2	≤ 150 cm								
		2	≤ 180 cm								
	Zonda® XL 10	1	≤ 120 cm	Q3	✓			✓	✓	✓	
	Zonda® XL 15	2	≤ 120 cm	Q2	✓			✓	✓		
		2	≤ 150 cm								
		2	≤ 180 cm								
	Zonda® XL 15	1	≤ 120 cm	Q2	✓			✓	✓		
		1	≤ 150 cm								
	Shamal® XL 15	2	≤ 120 cm	Q2	✓			✓	✓		
		2	≤ 150 cm								
		2	≤ 180 cm								
	Shamal® XL 15	1	≤ 120 cm	Q2	✓			✓	✓		
	Shamal® XL 20	2	≤ 120 cm	Q3	✓			✓	✓	✓	
		2	≤ 150 cm								
		2	≤ 180 cm								
Shamal® XL 20	1	≤ 120 cm	Q3	✓			✓	✓	✓		

# Fixing system properties

## FIXING ACCESSORIES



Profile cover  
BSLC01  
SAP133171



Standard profile  
Raw : BSLP11 (SAP135306)  
Anodized : BSLP10 (SAP132681)



Stabilizing device - BSLR  
SAP132682 (88 cm)  
SAP132683 (108 cm)  
SAP132691 (128 cm)  
SAP132692 (148 cm)  
SAP132693 (168 cm)



Aluminium tube 27 x 27 mm - BSLT  
SAP132678 (178,4 cm)  
SAP132679 (148,4 cm)  
SAP132680 (118,4 cm)  
SAP134082 (98,4 cm)  
SAP144554 (95,7cm)  
SAP144555 (115,7cm)  
SAP144556 (145,7cm)  
SAP144558 (175,7cm)



Self-drilling stainless steel fixing screw  
BSLF02  
SAP132699



Autan® XL plates  
Raw : BSLA01 (SAP134208)  
Anodized : BSLA03 (SAP132696)



Shamal® XL plates  
Raw : BSLA SAP142941  
Anodized : BSLA SAP142942



Harmattan® and Zonda® XL 10 plates  
Raw : BSLA07 (SAP135616)  
Anodized : BSLA08 (SAP135628)



Zonda® XL 15 plates  
Raw : BSLA02 (SAP134209)  
Anodized : BSLA04 (SAP132697)



Stainless steel assembly screws  
BSLF01  
SAP132698



EPDM interface  
Autan® & Shamal® XL 15  
BSLI01  
SAP132694



EPDM interface  
Shamal® XL 20  
BSLI  
SAP142940



EPDM interface  
Zonda® XL 10 & Harmattan®  
BSLI03  
SAP135615



EPDM interface  
Zonda® XL 15  
BSLI02  
SAP132695



90° Inox bracket (out Shamal® XL)  
BSLE01  
SAP137993

### Detail of fixing kit composition

SUNSCREEN PRODUCT	STANDARD MODULE DIMENSION (MM)	Sunscreen terracotta		Aluminium tube 27 x 27 mm		Stabilizing device		Fixing plates	EPDM interface	Fixing screw	Stainless steel assembly screws
		Qty.	Length mm	Qty.	Long. mm	Qty.	Length mm				
	1200 mm	4	294 mm	1	1184 mm	1	1080 mm	2	5	4	4
	1500 mm	5	294 mm		1484 mm		1280 mm		6		
	1800 mm	6	294 mm		1784 mm		1680 mm		7		
	1000 mm	1	980 mm	1	984 mm	1	880 mm	2	2	4	4
	1200 mm	1	1180 mm		1184 mm		1080 mm		2		
	1500 mm	1	1480 mm		1484 mm		1280 mm		2		
	1000 mm	1	980 mm	1	984 mm	1	880 mm	2	2	6	4
	1200 mm	1	1180 mm		1184 mm		1080 mm		2		
	1500 mm	1	1480 mm		1484 mm		1280 mm		2		
	1000 mm	1	980 mm	2	984 mm	2	880 mm	2	2	8	8
	1200 mm	1	1180 mm		1184 mm		1080 mm		2		
	1500 mm	1	1480 mm		1484 mm		1280 mm		2		
	1000 mm	1	953 mm	1	957 mm	1	880 mm	2	2	6	4
	1200 mm	1	1153 mm		1157 mm		1080 mm		2		
	1500 mm	1	1453 mm		1457 mm		1280 mm		3		
	1000 mm	1	953 mm	2	957 mm	2	880 mm	2	2	6	8
	1200 mm	1	1153 mm		1157 mm		1080 mm		2		
	1500 mm	1	1453 mm		1457 mm		1280 mm		3		
	1800 mm	2	875 mm		1757 mm		1680 mm		3		

# Cantilever fixing system

Autan® XL, Zonda® XL, Autan®, Harmattan®,  
Harmattan® XL

## FIXING SYSTEM

The layout is carried out beforehand by the installation company to determine the positioning of the profiles and the dimensions of the sunscreen kits.

Terracotta sunscreen products are strung on 1 or 2 27x27 mm aluminum tubes and are separated by a interface in EPDM, flexible material catching up with tolerances and the expansion of the terracotta.

The stabilization device to be placed on the aluminum tube comes by a spring effect stabilize the sunshades around the tube.

Fixing plates arranged at the 2 ends connect this kit to the vertical profiles. The aluminum tubes are assembled at their ends to the plates by screws. The plates are then fixed by self-drilling screws with vertical profiles.

An optional profile cover is provided in the upper part for finishing. The vertical installation is done exactly according to the same process with a simple 90° rotation.

For the sunscreen Autan®, Autan® XL, Zonda® XL, Harmattan® and Harmattan® XL, the installation is offset. For the Shamal® XL range the sunshades are installed between the profiles.

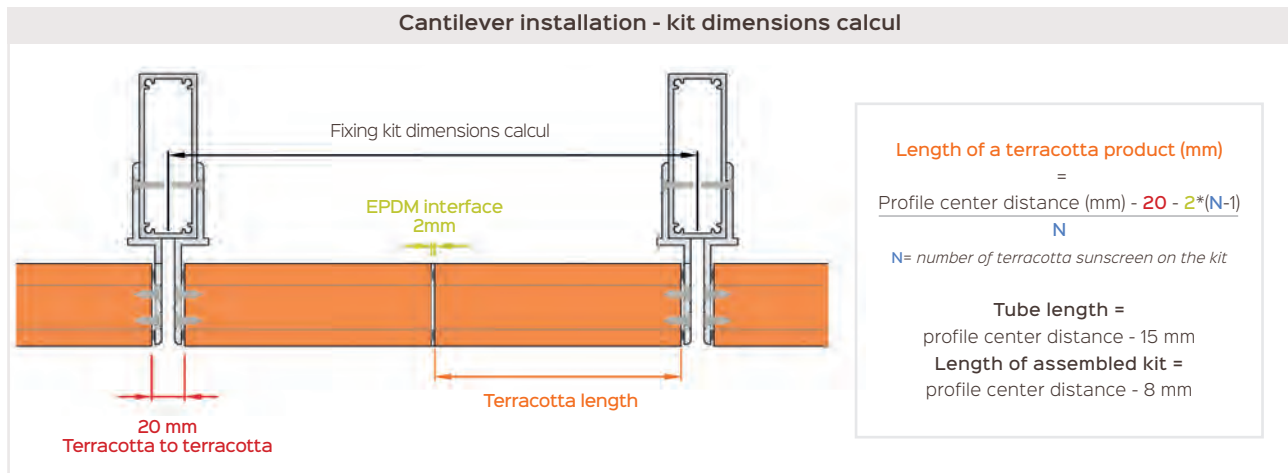

ZOOM ON ...  
installation  
guide video

[www.youtube.com/user/terrealvideos](http://www.youtube.com/user/terrealvideos)



# Cantilever fixing system

Autan® XL, Zonda® XL, Autan®, Harmattan®,  
Harmattan® XL

## FIXING SYSTEM

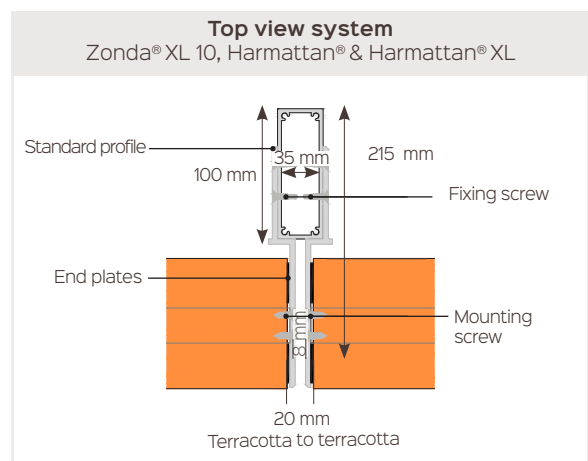
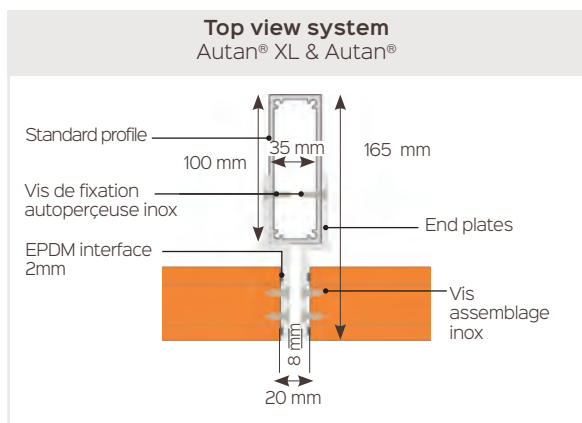
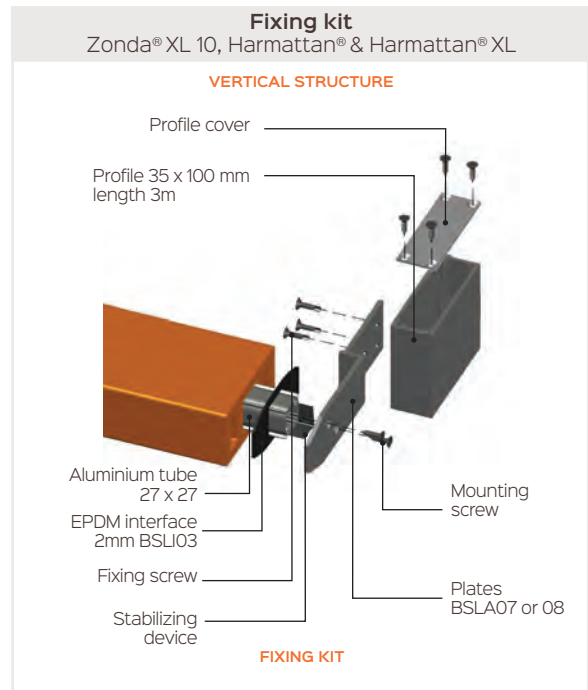
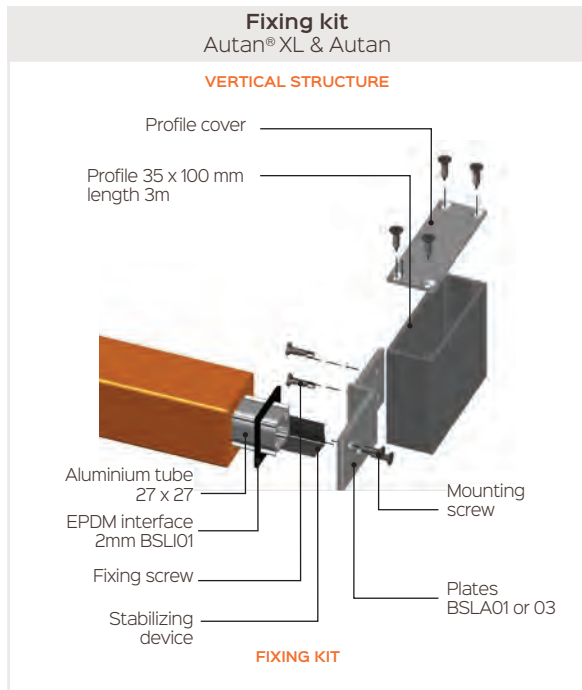

**Fixing kit**  
Zonda® XL 15

**VERTICAL STRUCTURE**

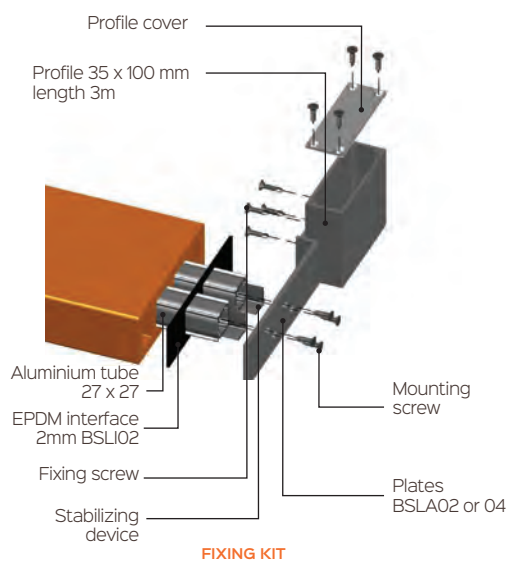

**FIXING KIT**

**CORNER DETAILS**

- 45° angle cut at factory is available
- Not available for Shamal® XL range

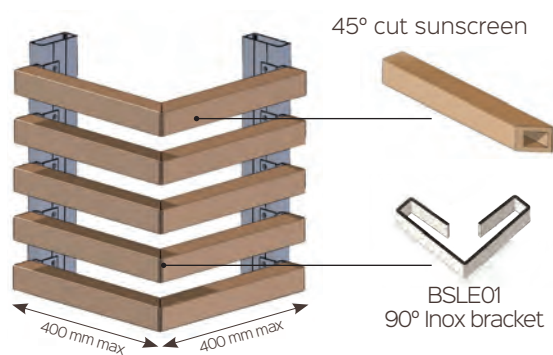

**Top view system**  
Zonda® XL 15

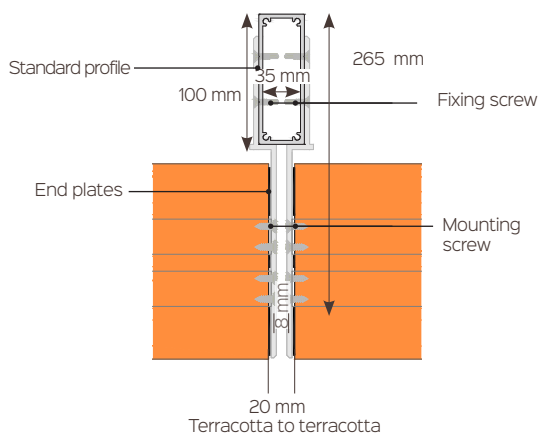

# Embedded profiles system

## Shamal® XL

### FIXING SYSTEM

Shamal® XL sunscreens are installed between profiles. Vertical installation is exactly the same process with a simple 90 ° rotation.

#### Tilting installation

The plate for the Shamal® XL 15 kit is the same as the Shamal® XL 20 kit. It allows the installation with 0 ° or 30 ° inclination.

Shamal® XL 15 can either overflowing the profile or flush with the profile in both inclination cases.

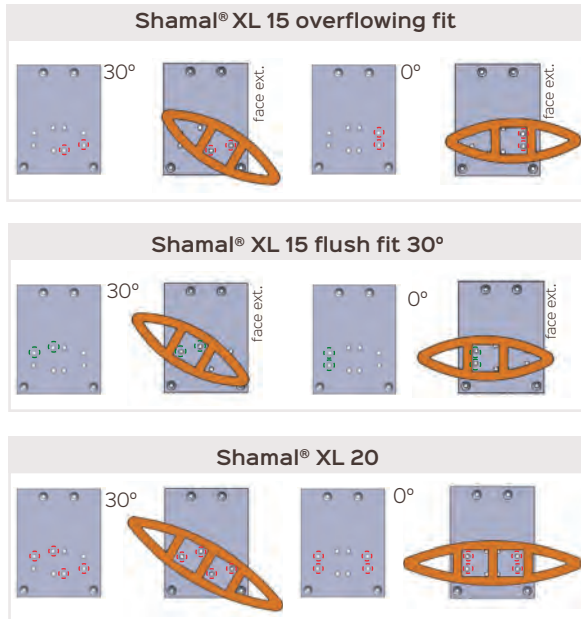

Position of tube assembly screws

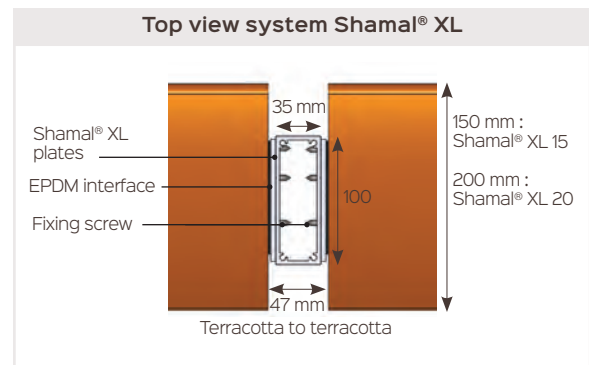
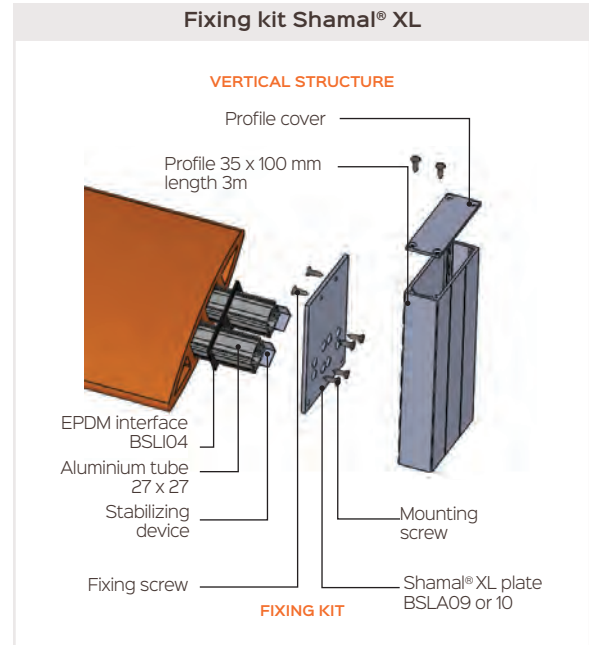

### Embedded installation - kit dimensions calcul

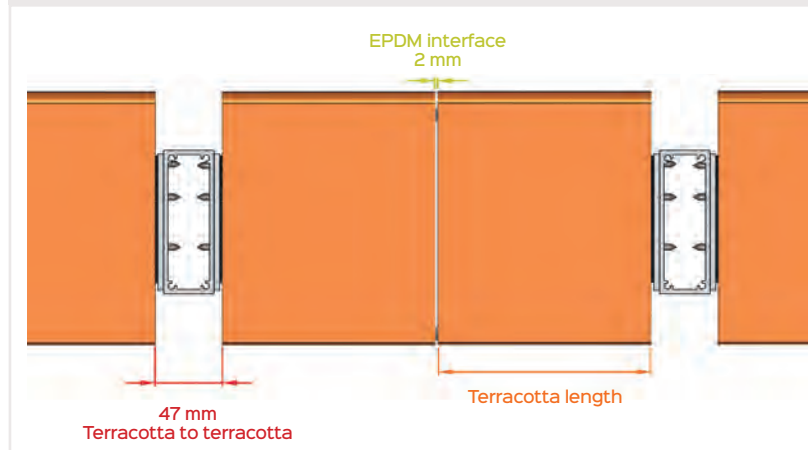

$$\text{Length of a terracotta product (mm)} = \frac{\text{Profile center distance (mm)} - 47 - 2 \cdot (N-1)}{N}$$

N = number of terracotta sunscreen on the kit

**Tube length =**  
profile center distance - 43 mm

**Length of assembled kit =**  
profile center distance - 35 mm

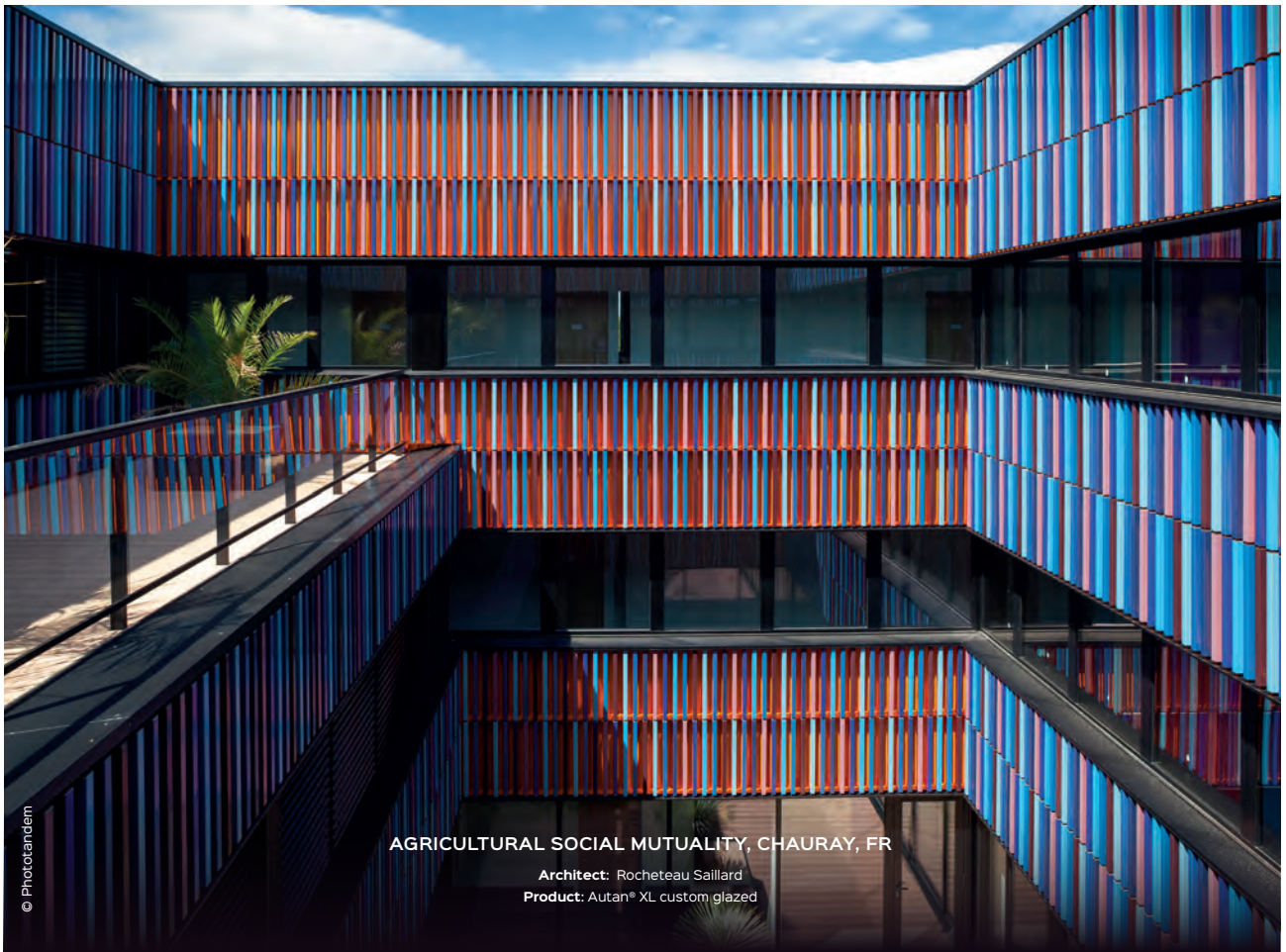

© Photostandem

**AGRICULTURAL SOCIAL MUTUALITY, CHAURAY, FR**

Architect: Rocheteau Saillard  
Product: Autan® XL custom glazed



**RESTAURANT POPULAIRE VORK, ACCUEIL DES ENFANTS ET BUREAUX, KORTRIJK, BELGIQUE**

Architect: B2AI  
Product: Autan® XL custom glazed

© Hervé Abbacchie



A CASA MUSEUM, SAO PAULO, BRASIL

Architect : RoccoVidal Perkins + Will  
Product : Autan® XL 03.Champagne

© Daniel Ducci

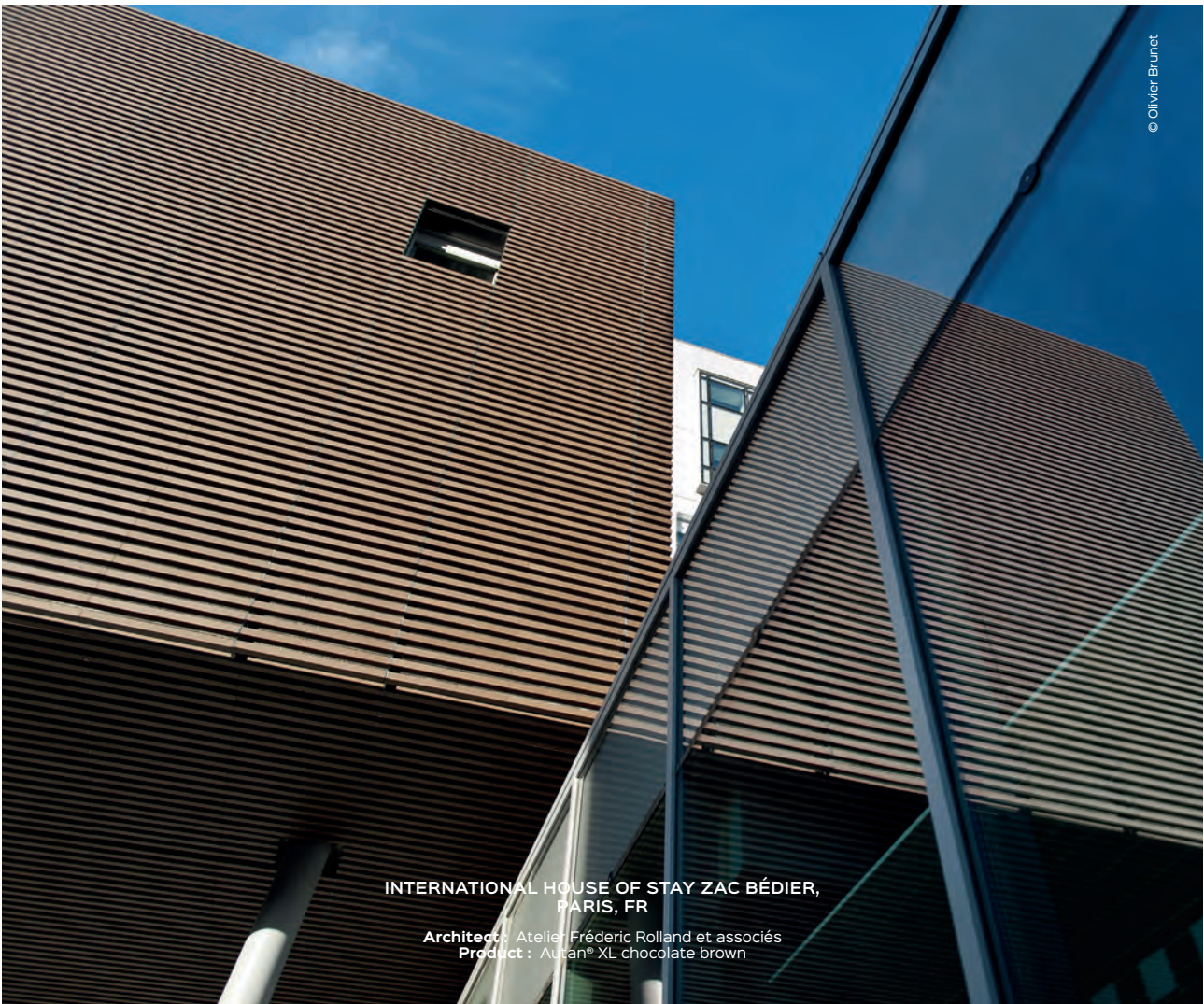

INTERNATIONAL HOUSE OF STAY ZAC BÉDIER,  
PARIS, FR

Architect : Atelier Frédéric Rolland et associés  
Product : Autan® XL chocolate brown

© Olivier Brunet



CSUMB UNIVERSITY, CALIFORNIA, USA

Architect : HMC Architects  
Product : Zonda® XL 07.Sahara beige

© David Wakely



LIBRARY, BIOT, FR

Architect : EPURE d'Architecture  
Product : Shamal® Red-orange, Champagne

© Christophe Mely



# Facing range

Bricks, mulots, brickslips

To beautify your walls, Terreal offers a complete range of clay brick in a wide range of colours, sizes and aspects. Aesthetic and easy to install, these terracotta facade products allow you the most creative achievements.



# Classic brick

Authentic terracotta beauty



Terreal's classic brick line offers a wide range of sizes and colours for a variety of architectures. From the most traditional to the most modern aesthetics, the variety of colours and shades offers a wide range of potential to dress up all the projects with elegance.

## STRENGTHS

- Wide variety of formats (up to 40 cm)
- Choice of traditional and contemporary colours
- Available in smooth or sanded finish
- Durable and maintenance free
- Resistant to external aggressions (shock, wind, frost)





**3**  
SKINS



Standard



Sanded



Flamed









Brick slips & angle brick slips



Solid & perforated brick



Solid & perforated mulot

	DIMENSIONS L X H X TH.	REF.CATALOGUE	WEIGHT / U	QUANTITY (10 MM JOINTS)	
	<b>Brick slips</b>				
	220 x 50 x 10 mm	PL21	0,22 kg	72 / m <sup>2</sup>	-
	220 x 50 x 14 mm	PL01	0,3 kg	72 / m <sup>2</sup>	-
	220 x 65 x 14 mm	PL03	0,4 kg	58 / m <sup>2</sup>	-
	280 x 50 x 14 mm	PL02	0,4 kg	57 / m <sup>2</sup>	-
	330 x 50 x 14 mm	PL05	0,45 kg	49 / m <sup>2</sup>	-
	<b>Angle brick slips</b>				
	220 x 105 x 50 x 15 mm	PL12	0,4 kg	-	17 / ml
	220 x 105 x 65 x 15 mm	PL14	0,5 kg	-	13 / ml
	280 x 140 x 50 x 15 mm	PL13	0,5 kg	-	17 / ml
	<b>Solid brick</b>				
	220 x 105 x 50 mm	B01	2,4 kg	72 / m <sup>2</sup>	-
	280 x 105 x 50 mm	B05	3,15 kg	57 / m <sup>2</sup>	-
	<b>Perforated brick</b>				
	220 x 105 x 50 mm	BP01	1,5 kg	72 / m <sup>2</sup>	-
	280 x 105 x 50 mm	BP05	2 kg	57 / m <sup>2</sup>	-
	400 x 105 x 50 mm	BP07	2,7 kg	41 / m <sup>2</sup>	-
	<b>Solid mulot</b>				
	220 x 50 x 50 mm	M16	1,1 kg	72 / m <sup>2</sup>	-
	<b>Perforated mulot</b>				
	220 x 50 x 50 mm	M01	0,75 kg	72 / m <sup>2</sup>	-
	280 x 50 x 50 mm	M02	1,1 kg	57 / m <sup>2</sup>	-

# Classic colours



Red



Pink



Red-orange



Violine



Red sanded



Pink sanded



Red-orange sanded



Violine sanded

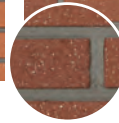
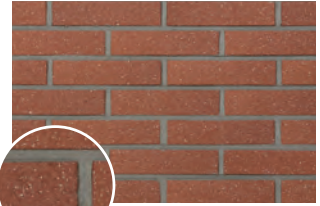

Jasmin



Magnolia



Brown



Ebony



Jasmin sanded



Magnolia sanded



Brown sanded



Ebony sanded

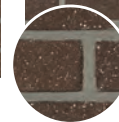

Beige



Stone colour



Champagne



Pearl grey



Beige sanded



Stone colour sanded



Champagne sanded



Pearl grey sanded



Snow white RQ



Black engobed



Mat biscuit (engobed)



COLOURS	DIMENSIONS AVAILABLE (MM)															
	BRICK SLIPS				ANGLE BRICK SLIPS				SOLID BRICK		PERFORATED BRICK		SOLID MULOT		PERFORATED MULOT	
	220 X 50 X 14		280 X 50 X 14		220 X 105 X 50 X 15		280 X 140 X 50 X 15		220 X 105 X 50		220 X 105 X 50		220 X 50 X 50		220 X 50 X 50	
Skin	Smooth	Sanded	Smooth	Sanded	Smooth	Sanded	Smooth	Sanded	Smooth	Sanded	Smooth	Sanded	Smooth	Sanded	Smooth	Sanded
Red	✓	✓	✓	✓	✓	✓	✓	✓	✓	✗	✓	✗	✓	✗	✓	✗
Red-orange	✓	✓	✓	✓	✓	✓	✓	✓	✗	✗	✗	✗	✗	✗	✗	✗
Pink	✓	✗	✓	✓	✓	✗	✓	✓	✓	✗	✓	✗	✗	✗	✗	✗
Violine	✓	✗	✗	✗	✓	✗	✗	✗	✗	✗	✗	✗	✗	✗	✗	✗
Brown	✓	✗	✗	✗	✓	✗	✗	✗	✗	✗	✗	✗	✗	✗	✗	✗
Ebony	✓	✗	✗	✗	✓	✗	✗	✗	✗	✗	✗	✗	✗	✗	✗	✗
Beige	✓	✗	✗	✗	✓	✗	✗	✗	✗	✗	✗	✗	✗	✗	✗	✗
Pearl Grey	✓	✓	✗	✗	✓	✓	✗	✗	✗	✗	✗	✗	✗	✗	✗	✗
Stone colour	✓	✗	✗	✗	✓	✗	✗	✗	✗	✗	✗	✗	✗	✗	✗	✗
Champagne	✓	✗	✗	✗	✓	✗	✗	✗	✗	✗	✗	✗	✗	✗	✗	✗
Jasmin	✓	✗	✗	✗	✓	✗	✗	✗	✓	✗	✓	✗	✗	✗	✗	✗
Magnolia	✓	✗	✗	✗	✓	✗	✗	✗	✓	✗	✓	✗	✗	✗	✗	✗
Snow white	✓	-	✗	-	✓	-	✗	-	✗	-	✗	-	✗	-	✗	-
Black engobed	✓	-	✗	-	✓	-	✗	-	✗	-	✗	-	✗	-	✗	-
Mat biscuit	✓	-	✗	-	✓	-	✗	-	✓	-	✗	-	✗	-	✗	-

✓ : Product in stock ✗ : Product not stored

# Glazed colours

Colours, sparkles and creativity



With a layer of coloured enamel glaze gently applied and bonded to the terracotta during the firing process, the glazed range is exuberant and offers a unique accompaniment for a variety of different architectural designs. Glossy or Matt finish, glazed bricks are a source of inspiration and offer to the Architects a possibility of rich and perennial expression to animate the facades and the rhythm of our environment.

## STRENGTHS

- An infinite choice of matte or shiny shades
- Durable and maintenance free
- Resistant to external aggressions (shocks, wind, frost)
- Fire resistant
- Wide variety of formats





DIMENSIONS L X H X TH.	REF.CATALOGUE	WEIGHT / U	QUANTITY (10 MM JOINTS)	
<b>Brick slips</b>				
220 x 50 x 14 mm	PL01	0,3 kg	72 / m <sup>2</sup>	-
220 x 65 x 14 mm	PL03	0,4 kg	58 / m <sup>2</sup>	-
280 x 50 x 14 mm	PL02	0,4 kg	57 / m <sup>2</sup>	-
330 x 50 x 14 mm	PL05	0,45 kg	49 / m <sup>2</sup>	-
<b>Corner brick slips</b>				
220 x 105 x 50 x 15 mm	PL12	0,4 kg	-	17 / ml
220 x 105 x 65 x 15 mm	PL14	0,5 kg	-	13 / ml
<b>Solid brick</b>				
220 x 105 x 50 mm	B01	2,48 kg	72 / m <sup>2</sup>	-
<b>Perforated brick</b>				
220 x 105 x 50 mm	BP01	1,5 kg	72 / m <sup>2</sup>	-

**18**  
COLOURS

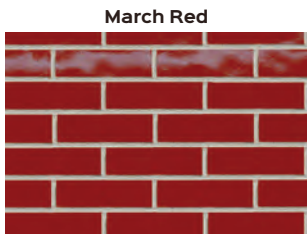

March Red



Red



Orange



Yellow



Lichen



Shadow land



Verdigris



Petrole blue



Cobalt blue



Violet



Calamine pink



Green



Glossy white



Mat white



Glossy light grey



Mat light grey



Glossy black

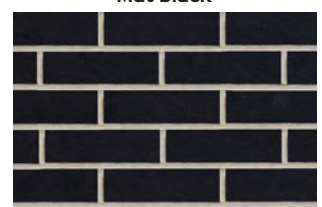

Mat black

# Hand-moulded brick

Raw beauty clay bricks



With its hand-moulded range, Terreal offers a wide choice of shades for creative architectures. This ancestral building material reinvents itself to meet the challenges of today. By the variety of its colours or the width of its formats, such as the MAAX very long solution, the hand-moulded bricks opens new fields to the architectural creation.

## STRENGTHS

- Raw material with irregular epidermis
- Exists in very great length 49 cm (MAAX brick)
- Durable and maintenance-free
- Resistant to external aggressions (shock, wind, frost)





Brick slips & corner brick slips



Solid brick



MAAX brick  
Long length brick 49cm



DIMENSIONS L X H X TH.	REF. CATALOGUE	WEIGHT / U	QUANTITY (12 MM JOINTS)	
<b>Brick slips</b>				
250 x 55 x 25 mm	PL06	0,5 kg	59 / m <sup>2</sup> (joints 10 mm)	-
<b>Corner brick slips</b>				
250 x 55 x 120 x 25 mm	PL17	0,7 kg	-	15 / ml (joints 10 mm)
<b>Solid brick</b>				
250 x 55 x 120 mm	BM01	2,8 kg	59 / m <sup>2</sup> (joints 10 mm)	-
490 X 40 X 115 mm	BM02	3,6 kg	40 / m <sup>2</sup> (joints 10 mm)	-

# Hand-moulded Colours

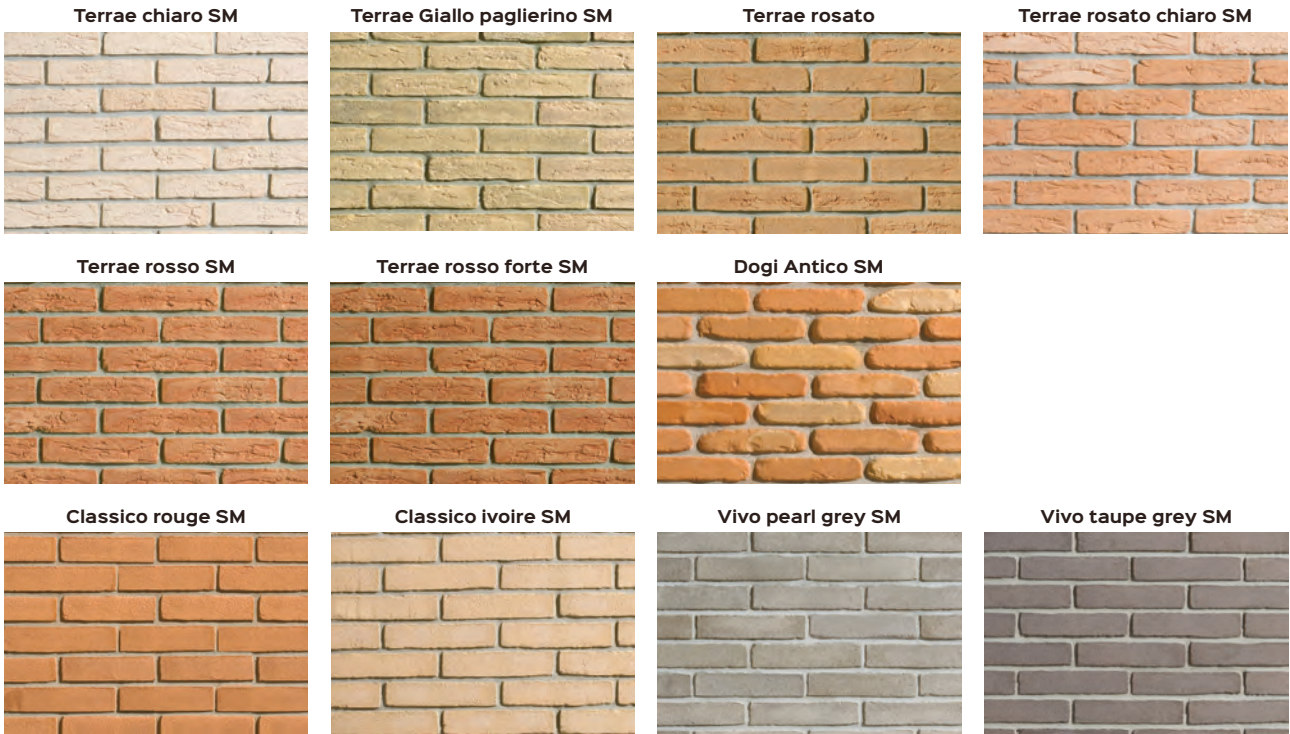

Available formats (mm)

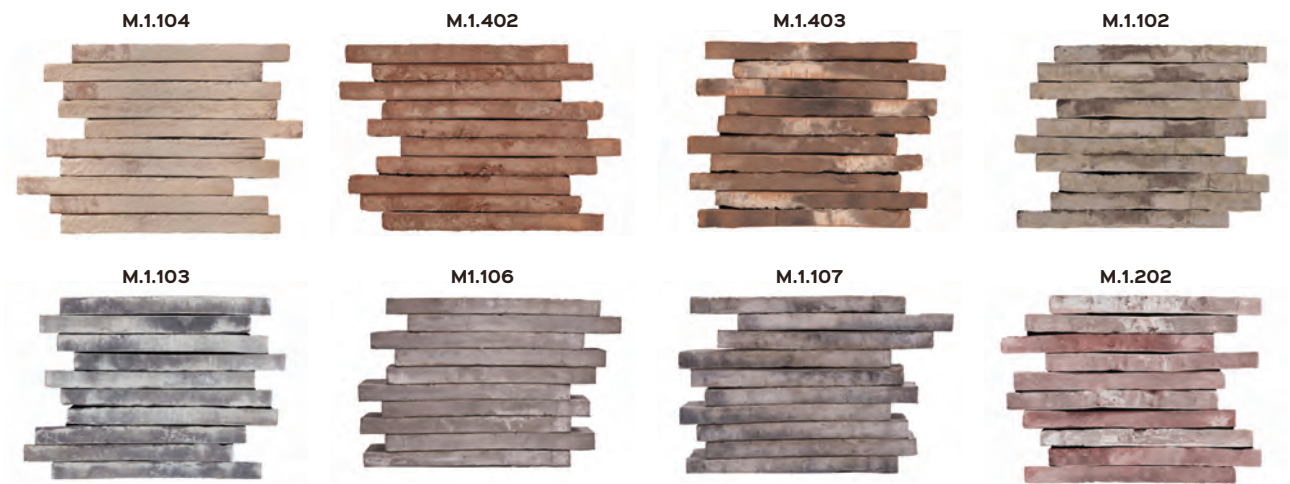

Available formats (mm)





**PRESCHOOL, RAVENNA, ITALY**

Architecte: Giancarlo de Carlo E Associati  
Product: Hand-moulded brick Chiaro

© DM Barcellona



© Les yeux carrés

**EHPAD RESIDENCE EMERALD, MAUBOURGUET, FR**

Architecte: J. Frassanito, pl-n associés, J-M Rombaldi  
Product: MAAX brick M.1.103



© OLUIS Asim

**PRIMARY SCHOOL, CASLANO, SWISS**

Architecte : Adolfo Zanetti  
Product: MAAX brick M.1.102

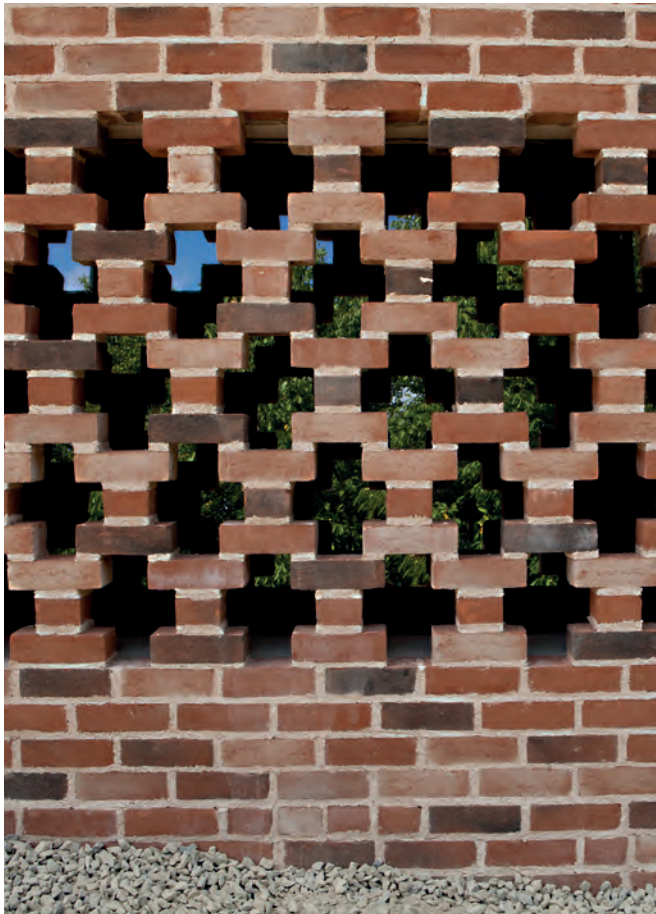



© Michel Dujheim

**SCHOOL OF MINES, ALBI, FR**

Architecte: JArchitecture Studio  
Product: Brick slips red

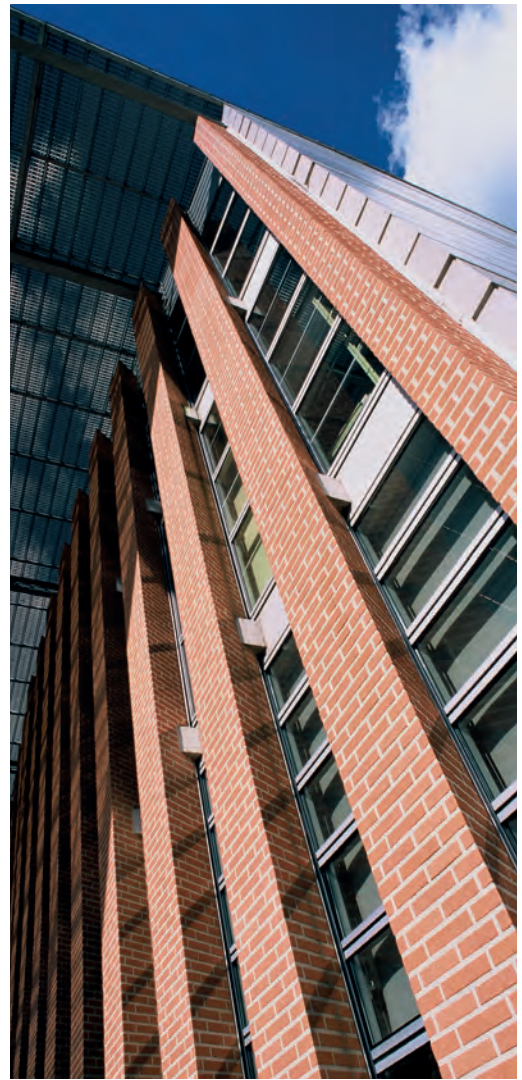

© Jean-Marie Monthiers

**UFR OF BIOLOGY, PARIS, FR**

Architecte: Jean Guervilly & Françoise Mauffret  
Product: brick slips brown and white glazed

Terreal has been a key player in clay building materials for over 150 years. Based on this unique experience, our group creates innovative solutions for the building envelope, through 3 activities : roofing, façade decoration and structure.

TERREAL SAS au capital de 87 776 320€ · SIREN 562 110 346 RCS Nanterre · FA1050/2020/06 · Design graphique : Agence Phase Partenaire

**TERREAL**  
Antipolis Bât. B  
37, Av Normandie Niemen BP 13 - 31701 Blagnac  
Tel. : +33 (0)5 34 36 21 00 Email : facade@terreal.com

[www.terrealfacade.com](http://www.terrealfacade.com)

  
**TERREAL**  
Building beauty